

# LEGEND SERIES

# SMARTMOTOR SM3410D AND SM3420D



**SM3410D**  
shown with  
standard D-sub connector



**SM3410D-PBP**  
shown with ProfiBus option  
"Plus" firmware



**SM3420D**  
shown with  
standard D-sub connector



**SM3420D-DNP**  
shown with DeviceNet™ option  
"Plus" firmware

DESCRIPTION		UNITS	SM3410D	SM3420D	
<b>Power</b>	Input	VDC	20 - 48 (max)	20 - 48 (max)	
<b>Environment</b>	Operating Temperature	°F (°C)	32 to 158 (0 to 70)	32 to 158 (0 to 70)	
	Enclosure Rating (approximate)		IP30	IP30	
	Storage Temperature	°F (°C)	-4 to 185 (-20 to 85)	-4 to 185 (-20 to 85)	
	Vibration (peak / continuous)	G	NA/7*	NA/7*	
	Humidity (non-condensing)	%	0 to 80	0 to 80	
<b>Performance</b>	Peak Torque (Tp)	oz-in (N-m)	144 (1.02)	432 (3.05)	
	Continuous Torque (Tc)	oz-in (N-m)	45 (0.32)	100 (0.71)	
	No Load Speed	RPM	5060	4310	
	Nominal Power	HP (kW)	0.16 (0.12)	0.24 (0.18)	
	Servo Update	Hz	4069	4069	
	PWM Frequency	kHz	33.3	33.3	
	Encoder	Type	Incremental	VDC	VDC
		Resolution	ppr (post-quad)	4000	4000
	Memory	Volatile	kRAM	32	32
		Non-volatile	kRAM	32	32
<b>Motor</b>	Commutation		6-step Trapezoidal	6-step Trapezoidal	
	Voltage Constant (Kv)	V/kRPM	9.20	10.80	
	Torque Constant (Kt)	oz-in/Amp (N-m/Amp)	12.5 (0.09)	14.6 (0.10)	
	Rotor Inertia (Jm)	oz-in-s <sup>2</sup> (10 <sup>-5</sup> kg-m <sup>2</sup> )	0.006 (4.24)	0.013 (9.19)	
	Insulation		Class A	Class A	
	Number of Poles (Np)		4	4	
	Winding Resistance (R)	Ohms	2.3	1.2	
<b>Input/Output</b>	Number (Type)		7 (5VDC TTL)	7 (5VDC TTL)	
	Input	Digital	+5V TTL sinking input	+5V TTL sinking input	
		Analog	sinking input, 10 bit	sinking input, 10 bit	
	Output	Sourcing	mA	5	5
		Sinking	mA	10	10
Encoder/Step & Direct Input Frequency	MHz	1	1		
<b>Communications</b>	Primary	Type	RS232; Serial (ASCII)	RS232; Serial (ASCII)	
		Speed	KBaud	2.4 to 38.4	2.4 to 38.4
	Secondary	Type	RS485; Serial (ASCII)	RS485; Serial (ASCII)	
<b>Physical</b>	Radial Load	lbs (kg)	15 (6.8)	15 (6.8)	
	Axial Thrust Load	lbs (kg)	3 (1.36)	3 (1.36)	
	Width	in (mm)	3.25 (82.6)	3.25 (82.6)	
	Length	in (mm)	3.5 (89)	4.1 (105)	
	Weight (Wt)	lbs (kg)	2.5 (1.13)	3.5 (1.59)	
	Shaft Diameter**	in (mm)	0.375 (9.5)	0.375 (9.5)	
	Pilot Diameter**	in (mm)	2.876 (73.1)	2.876 (73.1)	
	Bolt Circle Diameter**	in (mm)	3.875 (98.4)	3.875 (98.4)	

Performance spec based on 48VDC battery

Notes: \* tested at RMS acceleration for 20 minutes, \*\* check tolerance in drawings

# LEGEND SERIES

# SMARTMOTOR SM3410D AND SM3420D

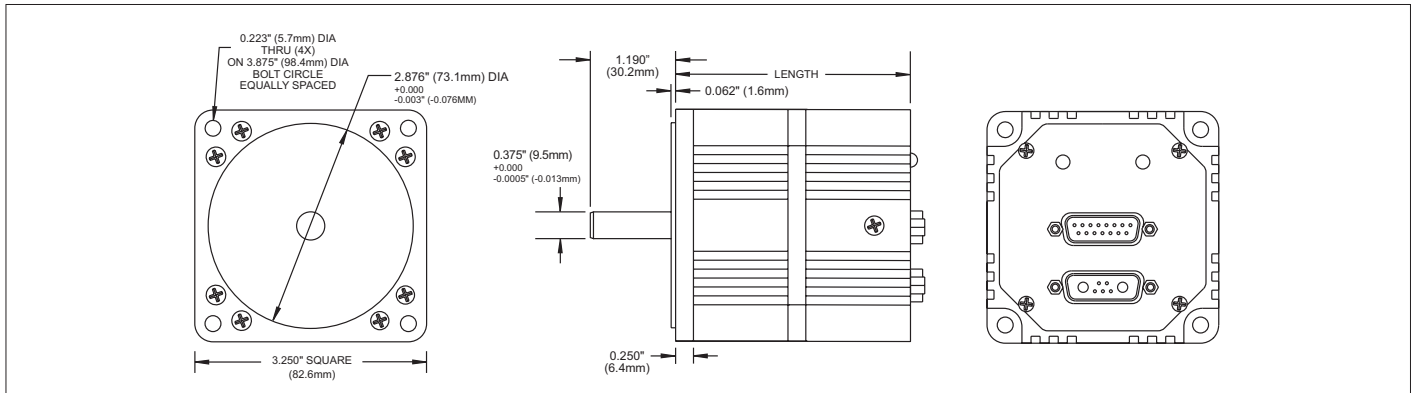

## SMARTMOTOR SM3410D

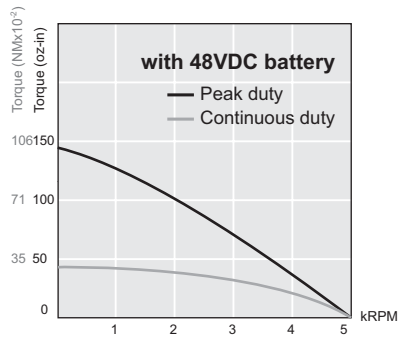

### Notes:

1. Custom windings are available on select SmartMotors. These special windings allow SmartMotors to achieve higher speeds or greater torque. Please consult factory for specific details.
2. Custom shaft lengths and diameters are available on select SmartMotors. Flats and keyways are common options found on motor shafts. SmartMotors can be purchased with various versions of these shaft modifications. Please consult factory for available shaft options.
3. Torque vs. Speed curve data is derived under dynamometer testing using a 48 VDC battery supply at an ambient temperature of 27°C (80.6°F).
4. Connector kits and cable options found on pp. 52 and 59.

## SMARTMOTOR SM3420D

