

BALDOR



Real-Time Ethernet Solutions

For the automation industry



The Real-Time Automation Language

Industrial Ethernet

A Brief Introduction

Ethernet has been widely used in industry for a number of years, primarily at higher levels, within factory floor environments for monitoring and managing production flow, from ERP (Enterprise Resource Planning) systems, and exchanging data between production machinery segments, where timing is generally not critical. Baldor's real-time Ethernet products take this technology down to control and machine level.

Standard Industrial Ethernet

The physics of Ethernet networking and an abundance of experience ensured its success in factory networking. Other, more dedicated network technologies (fieldbus systems), have dominated at a lower level, for the control and coordination of machinery and their component parts.

The sheer number of fieldbus systems, such as Profibus, DeviceNet and Modbus has weighed heavily on the industrial automation community. Designers often have to support a variety of hardware interfaces, different physical layers, protocols, service and diagnostic tools, within a single installation.

It is therefore not surprising that there is so much interest in the possibilities that a true real-time deterministic Ethernet solution could offer.

Real-Time Control Requires Determinism

The problem with standard Ethernet protocols for real-time control applications, such as motion control, is that they lack determinism. Put simply they are unpredictable in terms of when precisely data will arrive from one device to another, and when exactly a device will be able to send data or receive it.

Baldor's NextMove e100 multi-axis motion controller and MicroFlex e100 AC servo drive employ ETHERNET Powerlink, a proven real-time deterministic solution for automation.

Why use Ethernet for Control?

- › Total network visibility – tighter integration, improved information access and maintenance benefits.
- › Reduced training requirements of installation and maintenance personnel.
- › A single common physical layer from factory management level down to controllers.
- › Common cabling and infrastructure methodology in accordance with IEEE 802.3u specifications.



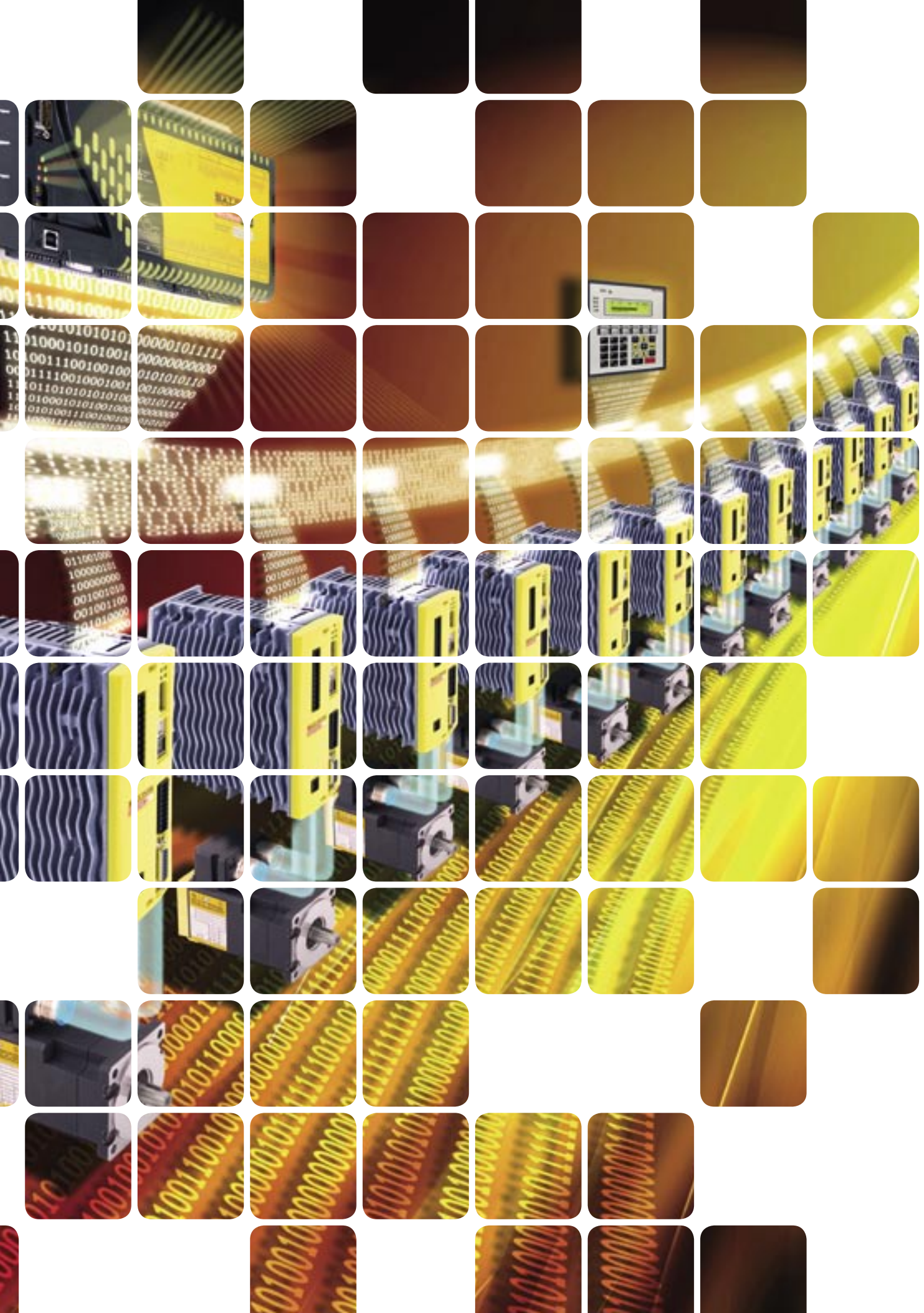

ETHERNET Powerlink

The Real-Time Solution

New choices of Ethernet technology are emerging, but one which stands firmly ahead of the rest as a proven technology, working in real applications, is ETHERNET Powerlink (EPL). It embraces standard Ethernet technology and infrastructure, uses standard CAT5e shielded cabling and does not compromise standard Ethernet frames in order to achieve its results. It does so with less than 1µS cyclic jitter for precise control, and with cyclic updates rates down to 200µS for fast system response.

Flexible System Architecture

In addition to these characteristics ETHERNET Powerlink is also well suited to both PC based solutions and platforms such as Mint® NextMove motion control products. This means that it can be used in a wide variety of system solution

architectures from PC based automation, embedded controllers and even decentralized intelligent drive technologies, since the manager technology is not dependant on a Windows platform.

› Determinism – The Key Problem

One of the key problems with providing a real-time system based on Ethernet is achieving determinism.

Standard Ethernet allows multiple devices to assume control of the network, resulting in data collisions. This means that network access and timings can not be predicted.

A process called CSMA/CD (Carrier Sense Multiple Access Collision Detection), resolves the conflict and allows one of the devices to gain dominance and transmit. The diagram below shows devices 2 and 3 both detecting network inactivity and trying to transmit, causing data collision.

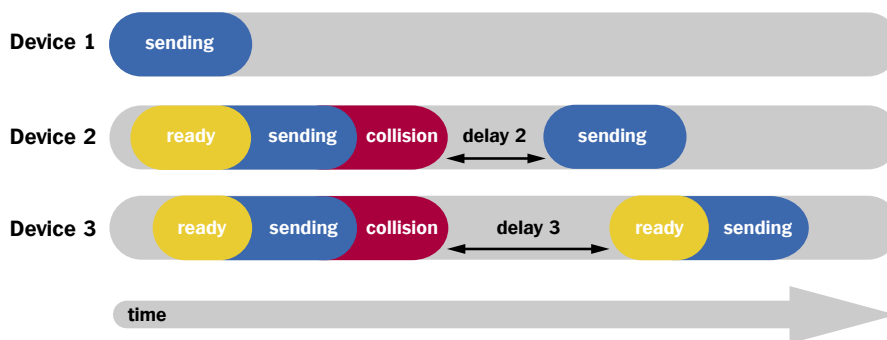

No Additional RTOS Required

Using Powerlink with Baldor's Mint products, there is no need for an additional real-time operating system (RTOS) extension, as there would be for systems based on a Windows platform. Instead all real-time tasks are managed by the Mint operating system, including ETHERNET Powerlink operation.

Open Standard Driven by Industry

ETHERNET Powerlink is a proven open standard for real-time Ethernet solutions. An industry based expert team of OEMs, end users and vendors, including Baldor, drive the technology to meet the market needs, and create new capabilities for users to leverage. The ETHERNET Powerlink Standardization Group (EPSG) has teams focussed on areas such as future protocol and capability developments, marketing, safety critical functions and product certification.

ETHERNET Powerlink is to become part of the IEC Standard – IEC 61784-2 "Digital data communications for measurement and control – Part 2: Additional profiles for ISO/IEC 8802-3 based communication networks in real-time applications". This is currently under development.



Characteristics of true real-time Ethernet

- › Standard Ethernet physical layer with cabling in accordance with IEE802.3u
- › Standard Ethernet message frames
- › Determinism
- › Timing precision of <math><1\mu\text{s}</math> jitter

And ideally...

- › Use standard hardware devices with no need for proprietary ASICs
- › Be supported by an open community of product suppliers
- › Be free of patents or intellectual property ownership of a single organisation

ETHERNET Powerlink addresses all of these requirements

› Determinism – The Key Solution

ETHERNET Powerlink (EPL) solves this issue by managing the nodes access to the network within allocated time slots. Data exchange with each node takes place under control of a manager node.

This approach, by design, prevents collisions from ever occurring and ensures that data is exchanged precisely and on schedule - hence determinism is achieved with cycle times down to 200µS.

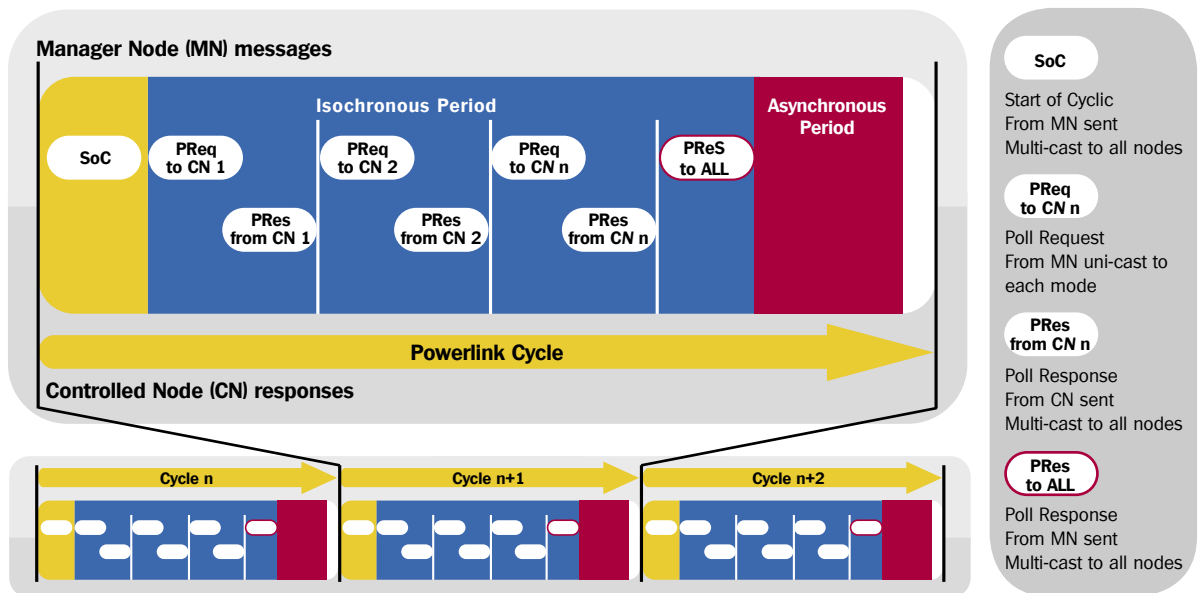

Network Security, by Design

Total network visibility, while a major advantage, is a weakness that could be exploited by hackers. Powerlink operates as a *protected segment* by design, and connects to a non-deterministic Ethernet network via a gateway/router device. This gateway acts as a defensive barrier against attacks with features such as MAC (Media Access Controller) address filtering and built-in firewall. These are features that traditional networking technicians are familiar with.

Total Network Visibility

By maintaining the core aspects of standard Ethernet, Powerlink provides visibility of all devices on the network, Mint devices even provide visibility of their subnet devices such as CANopen I/O. This allows any device to be monitored, configured, diagnosed, or upgraded from any accessible network point. With Mint motion controllers this can even be via the USB port of the network manager, simplifying commissioning and machinery production.

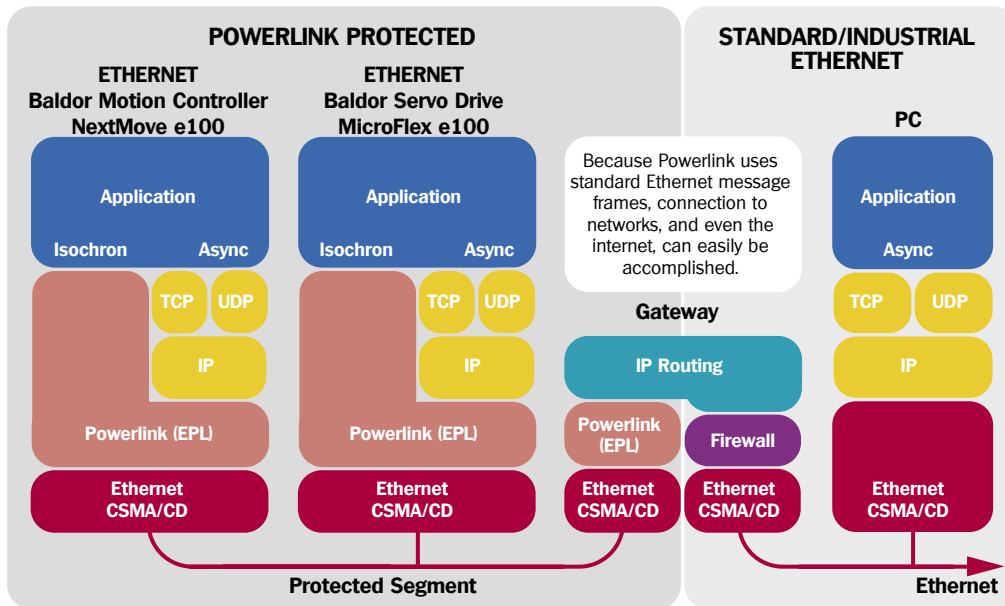

Block diagram showing a Powerlink protected network segment connected to a standard Ethernet network via an EPL gateway/router with integrated firewall.

Jitter Free Operation

Controlling devices such as servo drives requires precision in timing of information updates. This means the communication cycle has to be consistent, without significant deviation, otherwise artificial variations in demand torque, speed or position occur resulting in degraded performance. In addition system timing of critical operations vary, and inevitably affect final production quality. Powerlink meets this requirement by achieving less than $1\mu\text{S}$ variation (or jitter) and distributing a *system clock* to all connected devices.



Bandwidth Optimization by Multiplexing

Powerlink provides the freedom to prioritize nodes on the network by multiplexing within time slots. In the diagram below, nodes 1, 2 and 3 are critical and are updated every cycle. Nodes 4 through 11 share time slots. This allows fast cycle times to be maintained with optimized network bandwidth.

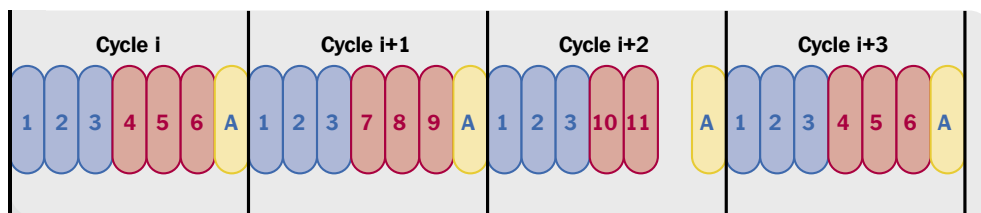

Every Cycle: 1, 2, 3 Multiplexed: 4-11

Time

This diagram shows network bandwidth optimization by multiplexing nodes within time slots.

Leverage Real-Time Ethernet with the Power of Mint[®]

To build upon the power of a real-time digital network solution, you need a responsive, flexible and powerful software language. Mint provides a wealth of features to leverage the power of ETHERNET Powerlink in next generation machine automation.

Mint offers a higher degree of flexibility to describe the application tasks and build upon the power of Ethernet. Features include advanced motion capabilities, multitasking, system events, simplified control of EPL/CANopen DS402 positioning drive axes, and common tasks such as I/O logic manipulation and HMI interaction.

In addition Mint is supported by free ActiveX controls for host PC development and an embedded C option.

- › Mint multitasking software
- › ActiveX interface for Windows based automation
- › Embedded C programming for ultimate performance



Real-Time Ethernet

Imagine the possibilities and realize them today

As designers, your engineers are constantly pushing technology to its limits. Their imagination is constrained by the performance of traditional fieldbus systems and device hardware. Real-time industrial Ethernet is expanding these boundaries, providing the platform for next generation machine development. Based on IEEE802.3u and other standards, and solving the issue of determinism without compromising standard Ethernet message frames, ETHERNET Powerlink is a technology which combines bandwidth, functionality, flexibility and scalability for innovative new system designs.

Plug & Play – Connect & Control

For drive control, ETHERNET Powerlink provides a digital replacement for traditional control signals, analog demands and feedback signals. Additionally, it absorbs and expands on the function of typical fieldbus devices and networks. The plug & play technology provides a truly networked solution allowing access to all devices from a single point of access. As a result, installation costs and system design cycles are drastically reduced. At the same time performance is enhanced considerably by replacing the analog world with digital purity.

Rapid Prototyping and Design – Save Time or try more Ideas, Faster

Designers using Ethernet can quickly alter system configuration, passing data instead of wired digital and analog signals. This improves performance and reliability, but also provides a rapid prototyping and development scheme for system control ideas to be tested and implemented, without hardware change. Configured data exchange between devices replaces complex wiring and reduces CAD layout requirements. Printed and archived data connection information documents the solution.

Centralized and Decentralized

Ethernet physics allow up to 100m (330ft) length between any two devices, this is ideal for distributing technology around a machine, or group of machines, and networking them together. I/O devices can be mounted next to sensors and valves, while drives can be local to the axes being controlled. This inherently allows designs to follow both centralized and decentralized approaches.

Typical System Architecture

The image below represents a typical control system of one or more machines connected to a corporate network.

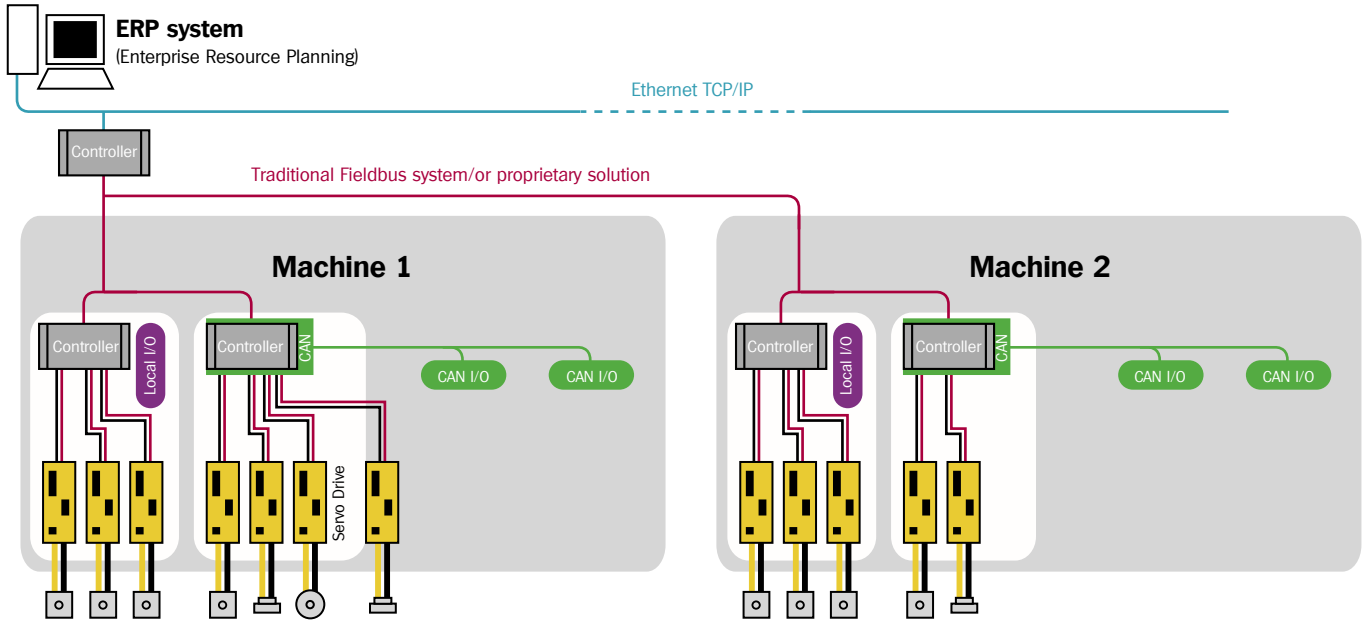

- › Multiple controller architecture – cost/complexity/extended development time
- › Typically 4 – 8 axes per controller, sometimes expandable by hardware expansion
- › Complex fieldbus communications – often proprietary, or limited in network capabilities (for example: parameter configuration, firmware update etc.)
- › Precise timing synchronization between controllers difficult to achieve
- › Fieldbus network typically requires optional interface on the drive and controller, and burden on main controller CPU

Mint based ETHERNET Powerlink System Architecture

The same system designed around Baldor's NextMove e100 multi-axis motion controller and MicroFlex e100 AC servo drive shows significant system benefits.

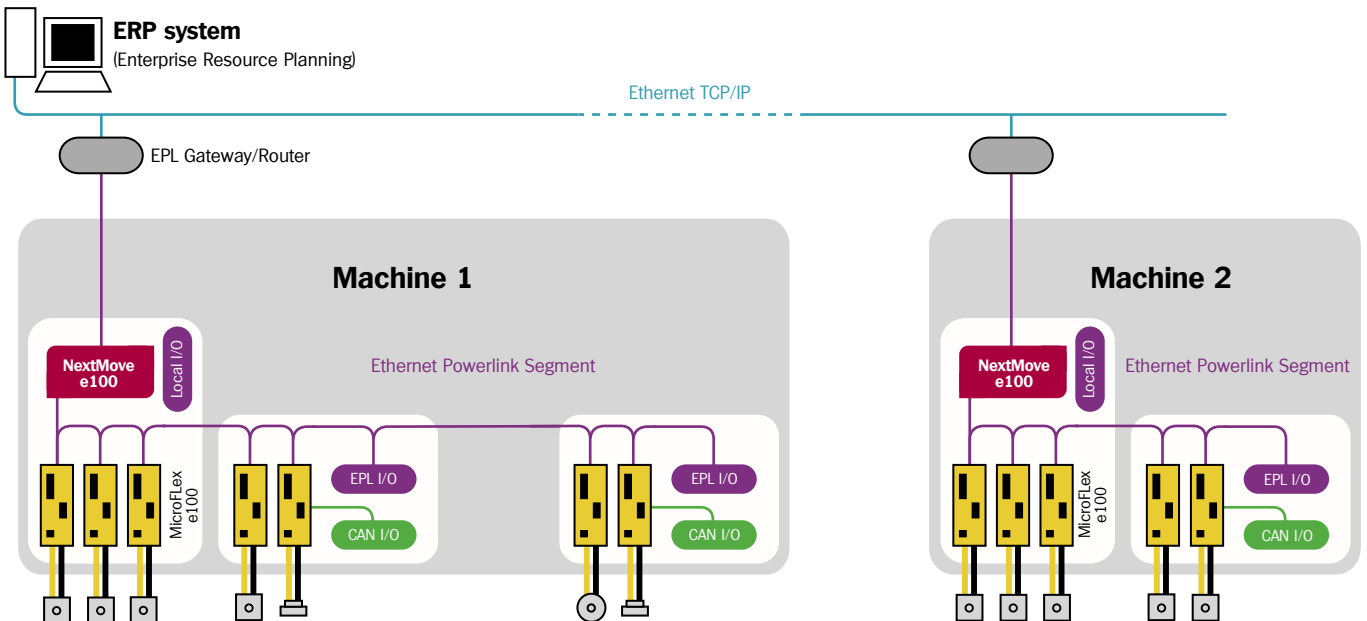

Advantages:

- › Fewer Motion controllers
- › Enhanced performance
- › Scalable system
- › CANOpen expansion
- › Reduced cabling complexity
- › Improved reliability
- › Total network visibility
- › EPL/CiA DS402 Positioning Drives
- › Shorter machine build time
- › Flexible design scheme
- › Centralized or decentralized

ETHERNET Powerlink Drive Control

One major aspect of Real-Time Ethernet is its advancement in control of drive technologies such as Servo and Vector drives. State of the art in terms of control network, ETHERNET Powerlink also excels in replacing traditional drive interfaces and fieldbus systems.

The table below highlights some of the benefits over traditional control wiring.

	Traditional Servo system	Ethernet Powerlink	Benefits
Installation	Analog demand – 2 core + Shield Simulated Encoder – 7 Wire + Shield Signal wires – Application dependant (typically enable and error) Fieldbus – Single cable	Single Ethernet cable (per axis)	Reduced system design Reduced installation time Fewer cables No soldering or complex connectors Single widely available cable type Fewer interconnections Improved reliability (fewer points of failure) Single Fieldbus physical layer and diagnostic tools
Performance	Depends on ADC and DAC resolutions Signal conversion delays and sampling rates Noise levels on signals Offsets/drift with temperature are often significant	Pure digital demand	No ADC/DAC dependency More consistent operation No drift, noise or offsets Higher resolution digital demand signals Reduced grounding / noise related installation issues
Communications	Via additional fieldbus connection Usually additional cost for hardware per node and cable cost Fieldbus type typical bandwidth 1Mbit to 12Mbit Limited device configuration / parameter access.	Ethernet Powerlink is a communications network 100Mbit bandwidth Complete device access	No additional costs (integrated into Baldor products) Higher bandwidth than traditional Fieldbus systems Tighter integration Provides single point of connection for commissioning all devices Improved diagnostics Total network visibility using standard Ethernet protocol TCP/IP

Powerlink Based - CAN in Automation (CiA) DS402 Positioning Drive Profile

Powerlink drives are based on the CAN in Automation (CiA) DS402 profile for positioning drives. This results in a drive technology which is inherently more flexible and intelligent. Drives not only provide velocity or torque regulation, but can also perform positioning tasks such as relative and absolute moves, and homing sequences. And all with minimal overhead on the motion controller. The NextMove e100 can coordinate up to 16 axes in closely coupled motion such as vectors, arcs and helical paths. It also manages DS402 drives which vastly expands the number of axes that can be controlled. DS402 is ideal for axes such as guides, indexers, conveyors, tension rollers and more.



MicroFlex e100 supports the CiA DS402 positioning drive profile, providing local positioning functions for simple axis control.

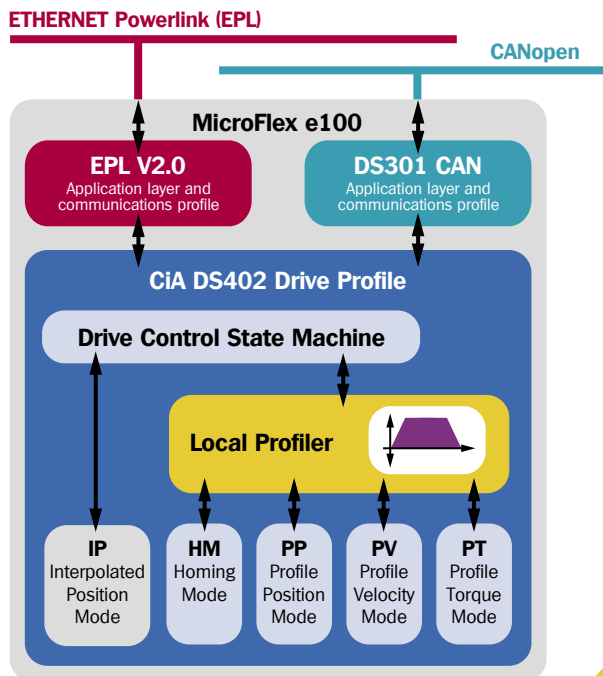

Additional Network Devices

A wide variety of additional system devices are available from Baldor and other vendor members of the ETHERNET Powerlink Standardization Group (EPSG).

For details visit - www.etherenet-powerlink.org

Powerlink Absolute Encoders

Absolute encoders can be added on Ethernet to create additional axis measurement or to act as machine cycle masters in 'line shaft' replacement and synchronization applications.

Powerlink I/O Devices

I/O blocks can be added to Powerlink to provide fast and distributed I/O which is synchronous to the control cycle.

Powerlink Gateway/Router

Provides a means of connecting ETHERNET Powerlink networks on to a factory LAN/WAN (Local Area Network and Wide Area Network).

CANopen Device Support

Baldor's NextMove e100 and MicroFlex e100 both feature an integrated CANopen port. Both products can manage a private network of CANopen DS401 I/O devices. In the case of the MicroFlex e100, I/O can be connected to any convenient drive. The MicroFlex e100 will manage the CANopen I/O and make this available, via Ethernet, to the motion controller where it can be used as local I/O. In essence you can have multiple independent CANopen networks distributed around the machine managed by each drive, but controlled centrally from the motion controller.

Baldor TCP/IP Mode via ActiveX

Not all applications require real-time coordination down to 200µS. Many simply require a number of axes to be managed, issuing simple move commands when necessary to individual or groups of axes. This principle is fully supported on Baldor motion and servo drives. This is achieved in *open* mode, without the normal cyclic update of Powerlink. ActiveX tools provide an interface for a host Windows application to issue commands such as relative moves, homing sequences, parameter changes, monitoring functions and even configuration and firmware download operations.

Mint[®] – The Programming Language for Automation

- › High speed compiled BASIC programming language for motion and machine control
- › Multitasking capability for motion, I/O, HMI and communication tasks, allows complex applications to be broken down into simpler, more manageable sub-tasks
- › Modular programming capability, including functions and subroutines, allows for code re-use and ease of debugging
- › Common programming interface for both NextMove and Baldor's intelligent drives reduces the learning curve
- › Comprehensive library of motion types including interpolated moves, CAM profiling, flying shears, gearing and more
- › Comprehensive Windows[®] tools including color keyword highlighting in the editor, software oscilloscope, online help, drive configuration wizard and auto-tuning
- › ActiveX[®] components (supplied free of charge) aid in the development of Microsoft Windows[®] front end applications

BASIC – the de-facto Programming Language

With nearly two decades of history, Mint[®] was designed from the outset around the BASIC programming language. It was understood then, and it is still true today, that BASIC is the de-facto programming language around the world. Now in its fifth generation, Mint fully embraces all the modern BASIC programming functionality including features such as multitasking, function and procedures, data types and local data. This functionality makes it easy to write and develop modular programs that are easily understood by others, easily maintained and easily re-used across different applications. Mint's new Code Library makes code re-use even easier by allowing snippets of code to be stored and used for other projects. This is just one of the many features in the Mint development front end, Mint WorkBench, which are designed to get you up and running quickly.

More than just Motion Control

Mint excels in motion control applications, but is equally at home in HMI interaction, communications, I/O handling and complex mathematical functions. While some choose a standard 'open' PLC language platform that offers a 'standard' set of motion features, those looking for an edge will find it in the advanced motion capabilities of Mint. Many industries at the cutting edge of motion control realize this and find PLC technology limited in its capabilities for motion control.

Realizing that today's applications are more demanding, more precise, more dynamic and more complex, Mint focuses on providing creative features, advanced motion capabilities and features for the user to innovate the application solution.

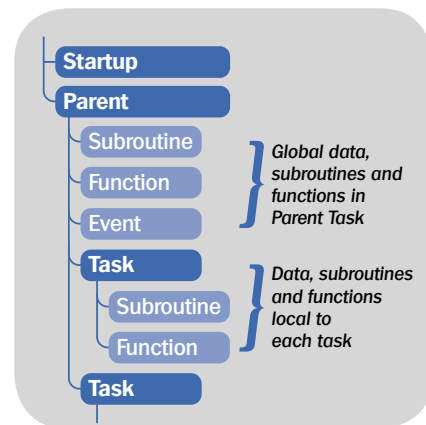

Multitasking Streamlines Program Flow

With many devices to control and machine functions to coordinate, it often helps to be able to structure code into specific tasks and allocate the resource dynamically at runtime. Multitasking is one of the key features of Mint. Numerous software tasks can be written, initiated, suspended, terminated and prioritized at will, to optimize workflow and improve machine performance. In its simplest form consider that separate program tasks can be allocated to functions of motion control, HMI interaction, I/O control, communications and much more, producing a structured programming solution and ensuring more dynamic program flow.

Time Critical Functions Handled with Ease

Time critical functions, such as responding to the change of state of inputs are handled with ease by Mint's event structure. Using the event structure within Mint is more efficient and faster than polling the state of an input. Events can be triggered for digital inputs, move buffer low, errors, position latches and more.

With a large onboard memory, the multitasking capabilities of Mint can also be used to store multiple programs, for example, to define machine recipes. Each task can have its own independent data storage, functions and subroutines.

Comprehensive Library of Move Types

Move buffer enables continuous motion

All axes have a flexible and powerful move buffer system that allows multiple move commands to be loaded and then executed. Each entry in the move buffer can contain a unique identifier, independent Speed, Acceleration, Deceleration and Jerk settings. A configurable *Move buffer low* system event will trigger either a Mint routine or ActiveX service which you can customize to refill the buffers. Output transitions states and pulse times and even dwell times can be loaded into the move buffer to ensure they are synchronous to the axes motion.

Motion Profiles – Positional Moves

Mint offers many flexible move types to suit your application requirements.

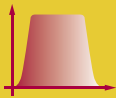

Absolute and Relative: With its own speed, acceleration and deceleration defined (including trapezoidal and S-ramp profiles).



Interpolated moves: Using the deep move buffer, multiple linear and circular moves can be blended to create continuous complex motion paths. Inter-vector angle control allows complex paths to be executed with minimum disturbance. Feedrates and digital outputs can be loaded with each move for complete synchronization.



Tangential Knife: Combined with interpolated motion, one axis can be defined as a knife axis and will follow the tangent to any 2D application.



Helical Interpolation: For 3 axes, defining a helical move in 3D space.



Speed Control: A jogging function allows the motor to run indefinitely at a defined speed, in position control.



Splining: Allows a stream of moves, defined in terms of position, velocity and time, to be blended for continuous and smooth motion.

Motion Profiles – Master/Follower

Master follower applications can be geared off any of the encoder inputs, pulse/direction input, virtual axes or from an ETHERNET Powerlink encoder.



Electronic Gearbox & Clutch:

Enables two or more shafts to be linked with a programmable ratio. Any axis can be geared to any other axis. Clutch allows precise start and stop distances when synchronizing.

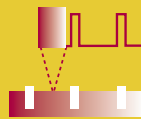

Registration on the Fly: An offset move can be superimposed on the gearing move for position correction. This can be triggered from any of the registration inputs or by Mint.



Electronic CAM: Replaces traditional mechanical CAMs with servo/vector/stepper motor and software programmable profiles (relative or absolute).



Flying Shear: Allows position synchronization of a slave axis to a master, with defined acceleration and deceleration profiles - all linked by software to product movement.

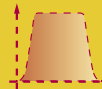

Virtual Axes: Allows a profiled move to be executed without connection to external hardware. Can be used to test applications or as a virtual master.

Refer to Catalog BR1202-B for further information on the Mint programming language.



Mint[®] Machine Center Design and Create

Mint[®] Machine Center (MMC) provides a suite of tools to design, create and ultimately control your application, and can streamline your design cycles to save you time and money.

Design

A graphical tree-view interface represents all connected devices within a Mint network configuration. Devices can be added offline and the design implemented later, or the system simply scanned and devices detected.

This view is useful for visualizing all devices and starting commissioning. The *machine view* allows you to group devices into a logical order other than by address or type sequence of the network view. By allowing group names to be defined and each device given a logical name, you can create a custom view of the system which represents your application or machine configuration.

Configure

Making configuration changes to any device is simple. Click on the device icon within the network or application view, to launch the Mint Workbench directly connected to that device. Wizards, auto-tuning, and online help have been designed to guide you through the process of device configuration.



Document Project with Document Links, Web Links and Images.

MMC allows you to create document links to specifications, images, web links, user manuals and reports. These describe the application design, and simultaneously document the system as part of the project file.

Automated Web Update via SupportMe™

If you have web access, you can take advantage of the web updates feature. This will check for firmware updates for your specific motion controller or drive. The firmware files can be downloaded and installed into a maintained database on your PC, allowing you to use them as required.

SupportMe™ Technical Support

When faced with difficulty, Baldor's SupportMe™ feature will gather a host of important information from the controller. An e-mail will be generated automatically, offering you the option of attaching programs and additional files. This can be sent directly to your chosen local technical support contact, providing an efficient support mechanism to help you get back up and running. (Requires e-mail client).

Wizard Setup Minimizes Knowledge Requirement and Saves you Time.

Wizards have been designed to automate many tasks, reducing set up time and minimizing knowledge required by incorporating the knowledge of skilled technicians. These step-by-step guides automate processes such as network configuration, drive configuration, auto-tuning and more.

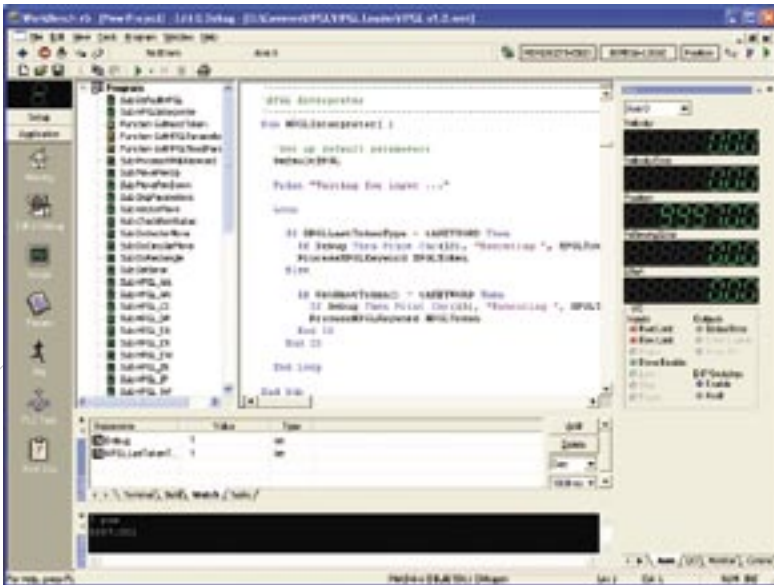

Integrated Context Sensitive Help

A press of the F1 key takes you to the Mint integrated online help, instantly presenting you with information relating to the feature you are trying to use. This could be a stage in the drive commissioning wizard or the highlighted Mint keyword in the program editor.

Program Navigation

The tree-view Program Navigator provides structural overview of your program and a fast method to find code sections, tasks, functions or subroutines. Simply click on the name of the code section you are looking for. You can use it to insert new tasks, subroutines and functions from the Program Navigator pop-up menu and reorganize your program.

Modular Code that can be re-used – The Mint Code Library

A new code repository allows you to easily store and re-use functions, subroutines or entire Mint programs for future use. These code segments can easily be recalled and inserted into new projects, streamlining code development. Simply select and insert code segments into your current program.

Software Oscilloscope

A 6 channel software oscilloscope can be used to capture and display all the diagnostic information you need to tune a system, diagnose problems, or to fine tune program operation and machine cycles.

- › 6 channels of display
- › Cursor measurement
- › Save/open/print functions
- › Independent axes scaling
- › Plot X against Y position
- › Trigger and repeat capture modes

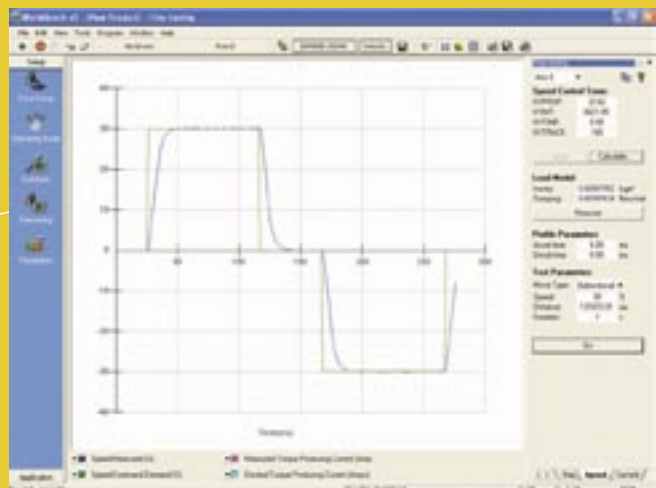

NextMove e100

Real-time Ethernet Motion Controller

- › **ETHERNET Powerlink - integrated hub**
- › **16 axes of interpolated motion**
- › **Connect up to 240 Ethernet devices including drives, I/O and encoders**
- › **CANopen network manager for low cost expansion**
- › **RS232/485 and USB communications**
- › **Multitasking Mint[®], ActiveX[®] or C programmable**



The NextMove e100 builds on the proven NextMove controller family and now integrates management of a real-time Ethernet network. Drives, I/O devices, sensors, absolute encoders and more can be added to the Powerlink network and controlled from the Mint programming language. Ethernet greatly simplifies system design and installation and simultaneously expands the capabilities of the NextMove e100 as a machine control platform.

Interpolation on 16 Axes

NextMove e100 can perform interpolation on 16 axes, as either a single coordinate group or as multiple coordinate systems operating independently with their own scale factors and move buffers. Alternatively all 16 can operate as independent axes.

Manage up to 240 Positioning Drive Axes

Up to 240 DS402 positioning drives, such as the MicroFlex e100, can be managed. These axes provide simple point-to-point motion, homing sequences, jog control and torque demand functions. Example applications include guide axes, indexers, conveyors, tension rollers and more.

Up to 255 Addressable Devices

Powerlink devices have an addressable range of 0 - 255, with some addresses reserved for special purposes, you are able to add up to 240 drives, I/O devices, encoders, gateways and other Powerlink devices.

Integrated Two Port Ethernet Hub

Connecting multiple devices on the Ethernet network is simplified by an integrated 2 port hub. Simply daisy chain the connection to the next device in the system.

Node and IP Address

The node ID (address) is easily set by two rotary hexadecimal switches, the IP address is then automatically derived from this.

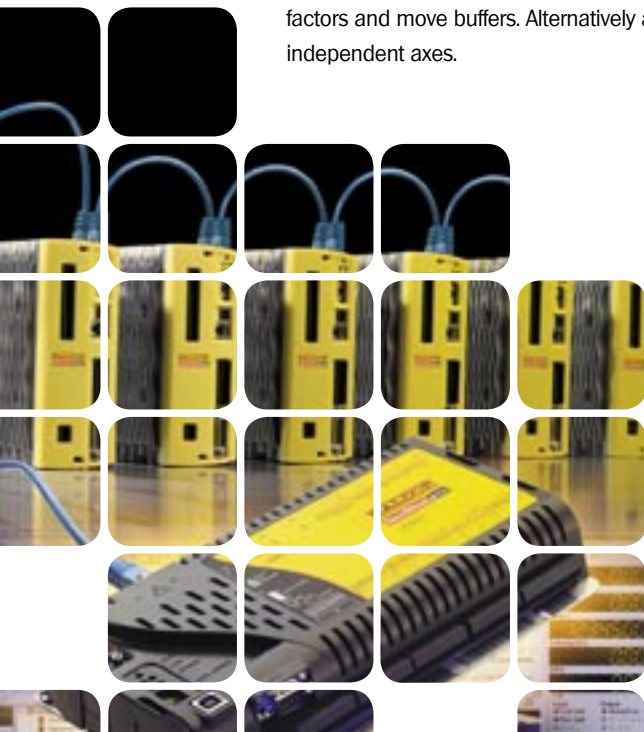

TCP/IP Communications via ActiveX

In addition to the deterministic mode of ETHERNET Powerlink, the NextMove e100 can also operate in an *open* mode using TCP/IP messaging. This feature is supported by Baldor's Mint ActiveX tools, which can provide control of a network of drives from a Windows® based PC. In this mode the Ethernet interface acts as a standard TCP/IP network port.

USB Interface with ActiveX support

An integrated USB interface provides a configuration and programming port. It allows access to the entire network from a single point, providing access to all Baldor devices connected to the Ethernet port of the controller. Mint ActiveX tools also allow use of the USB port for HMI or control purposes.

CANopen Manager

Use the CAN interface to manage a separate CANopen device network, to expand I/O, add a Baldor HMI, or control pneumatic valves and much more. Selecting from over 440 worldwide vendors of CANopen devices, there are vast possibilities for expansion.

State of the Art Design

The e100 family of motion controller and drives utilize a processor to deal with all communications requirements, leaving the main Digital Signal Processor (DSP) to handle time critical motion tasks. The communications core even deals with message redirection where messages were not intended for this device. For example, information from the USB port can be redirected to Ethernet devices.

A Field Programmable Gate Array (FPGA) core provides flexibility of design allowing updates to hardware to be issued by firmware update and not fixed in design as they would be with ASICs or any other discrete logic.

Serial interface for PLC, PC, HMI

A user selectable RS485/RS232 serial port is available and accessible in Mint to create a simple interface to devices such as PLC's, text displays, printers etc. Users can access the serial port directly to implement their own protocols, or make use of a predefined simple ASCII protocol (Host Comms Protocol) to simplify the task of host communications.



Baldor offers a comprehensive range of HMI panels.



Mint® – Advanced Motion Core

NextMove products operate on the Mint multitasking programming language. Based on almost two decades of experience in the motion control and automation industry, Mint provides a host of advanced motion capabilities such as interpolation, splines, electronic cams, gearing function. You can even design your own custom motion types when developing in embedded C.

On-board Digital and Analog Interfaces

Integrated digital and analog I/O provide the facility for system interlocks and logic control normally afforded by an additional PLC. This I/O can equally be expanded via Ethernet or CANopen.

Traditional Drive Interfaces

Integrated hardware interfaces provide a means of utilizing low cost, or existing drive technologies which do not yet support ETHERNET Powerlink, such as simple inverters, stepper drives and servo pneumatics.

Closed Loop / Servo or Vector

Local servo and vector axes are controlled from the industry standard $\pm 10V$ analog outputs and encoder feedback. The NextMove e100 has a fast 6 term PID loop for fine control of these axes.

NextMove e100 is matched ideally to Baldor's FlexDrive-II and MicroFlex™ range of servo drives, BSM servo and linear motor range for a complete servo control system.



Encoder Inputs and Fast Position Latch.

The servo control interfaces include three incremental TTL encoder channels which can also be used as additional position or velocity sensors. Alternatively, these can be used as *master axes* for synchronization applications. Four digital inputs can be used to latch the position of any of these encoders within 1 μ S and generate a software event. This is useful for registration based applications such as labeling and printing.

Open Loop / Stepper Control

Stepper axes can be controlled from any of the four onboard step and direction outputs. The stepper outputs can also be used to interface to Baldor's FlexDrive-II or MicroFlex™ servo drives, which combined with the three closed loop axes, can give up to 7 local axes of servo control.

Integrated Stepper Motor/Drive Technology

Baldor's new range of DSM integrated stepper motors/drivers are ideally suited for use with NextMove ESB. Combining both a high torque stepper motor and microstepping drive in one compact integrated package, the DSM motor/driver combination requires only power and pulse/direction signals in order to operate.



› Technical Data

Number of Axes	16 interpolated axes in single or multiple coordinate groups. Manage up to 240 independent DS402 positioning Drives (non interpolated).
Axis Type	ETHERNET Powerlink (EPL) v2 3 closed loop axes $\pm 10v$ interface with 5V TTL incremental encoder inputs 4 open loop axes - Stepper interface (Step & Direction outputs) 5V differential line driver (5MHz) or 5V Darlington open collector, single ended (500KHz max) selected by order option
Powerlink Device Type Support	EPL DS401 I/O devices for I/O expansion EPL DS402 Positioning Drives such as MicroFlex e100 EPL Absolute Encoders Manage up to 240 devices per network (approx.) Contact Baldor for information on additional 3rd party products supported.
Ethernet	Specification: 100Mbit - IEEE802.3u compliant Protocol : ETHERNET Powerlink V2 (EPL) and IP protocols TCP/UDP Interface : Integrated 2 port Hub for daisy chain connection Cable type : CAT5e Shielded cable, RJ45 connectors, Max 100m(330ft) each. Address: 2 off rotary HEX switches sets node and private device IP address
On-Board Memory	4MByte Flash for firmware and non-volatile program storage. 3MByte SRAM 32kByte FRAM for non-volatile variable data storage
Digital Inputs	20 opto-isolated 24VDC. 1mS sample rate. All inputs Interrupt capable. May be connected positive or negative common (for use with NPN or PNP output transistors) Software configurable for limits (forward and reverse), home, stop and drive error
Fast Inputs	The first 4 of digital inputs can be configured for high speed position capture of axis position 1 μ sec capture time

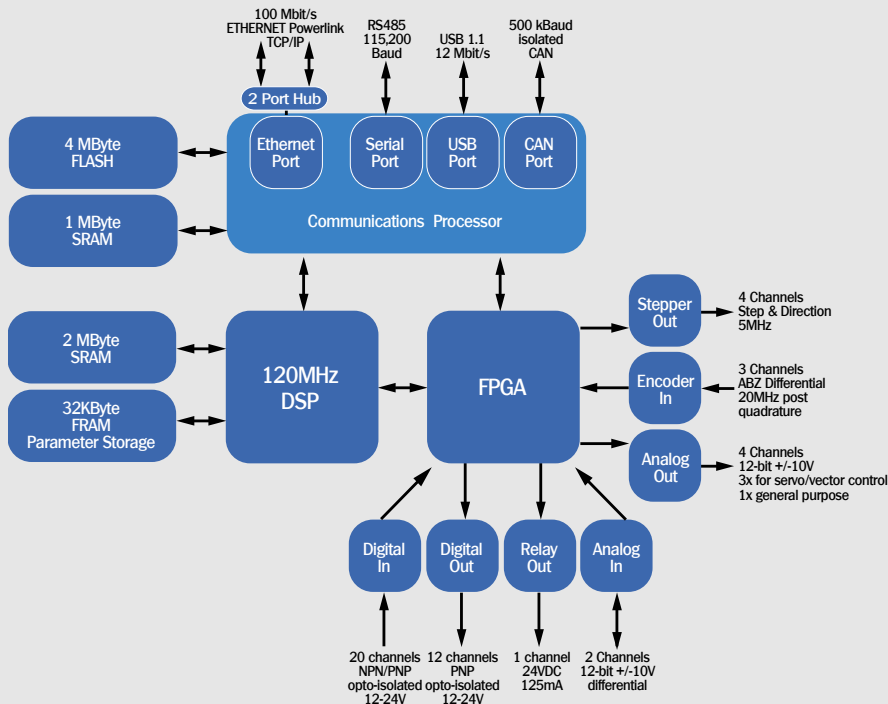

Ordering Information

Catalog Number	Description
NXE100-1616	NextMove e100 - 16 Axis motion controller: Differential stepper outputs
NXE100-1616S	NextMove e100 - 16 Axis: Single ended open collector stepper outputs for use with DSM integrated stepper/driver motors
CBL001-501	RS232 serial cable Note: 2m (6.6ft) USB cable supplied

See page 24 for the complete Product Ordering Information.

Digital Outputs	12 opto-isolated 12-24VDC PNP Software configurable for drive enable 50mA typical per channel, 350mA max load for single channel up to 500mA total for 8 channels
Relay Output	Single output for drive enable. Form C (SPDT) relay rated at 24V (150mA) Common, normally open, normally closed. Fail safe operation-relay de-energized on an error Function defined in Mint
Analog Outputs	3 outputs for drive command signals. ±10V, 12-bit resolution 1 general purpose ±10V 12-bit output
Analog Inputs	2 differential ±10V operation 12 bit resolution.
Serial Port	User selectable RS485/232 via 9 pin Sub-D. Maximum baud rate 115,200 USB 1.1 (12Mbit/sec) supported on Windows 2000/XP. A 2m (6.6ft) cable is supplied
CANbus Port	Single CAN port via standard 9 pin Sub-D connector. CANopen DS301 Support for CANopen DS401 I/O devices, Master functionality for peer-to-peer communications with other Mint nodes DS402 Positioning drives management
Power Requirements	24VDC ±10% : 70W
Environmental Limits	Operating Temperature 0°C to 45°C (32°F to 113°C)
Weight	0.85Kg (1.87 lbs)
Dimensions	L 262mm (10.3") : W 135mm (5.32") : H 45mm (1.77")
Programming	Mint® - Multitasking Motion Basic. Embedded C. Texas Instruments compiler must be purchased separately Windows 9X/NT/2000/XP via ActiveX control (Note: USB only supported on Windows 2000/XP) All Windows and embedded programming libraries supplied free of charge.

MicroFlex e100

ETHERNET Powerlink AC Servo Drive

- › Real-time Ethernet with integrated hub
- › CiA DS402 Positioning on ETHERNET Powerlink or CANopen
- › CANopen DS401 network manager for low cost I/O expansion
- › USB port for service / PC based control via ActiveX®
- › Linear and rotary motor control
- › Universal encoder interface
- › 115 – 230 VAC 50/60Hz supply
- › 3, 6 and 9 Amp versions with 200% peak capability



MicroFlex e100 is built on Baldor's expertise in servo drive technology. The advanced capabilities of real-time ETHERNET Powerlink provide superior performance, network integration and cost savings. MicroFlex e100 uses Space Vector Modulation (SVM) for superior motor control and efficiency. Numerous protection features are designed in for reliability and safety.



CiA DS402 Positioning Drive Profile

The core architecture of the MicroFlex e100 is based on the CAN in Automation (CiA) DS402 positioning drive profile. This describes the drive behavior (by means of an object dictionary) and provides the ability to perform basic positioning functions such as homing cycles, incremental and absolute moves, change of target position and profiled speed/torque control. This functionality, originally designed for CANopen based control, has been adopted and enhanced for use over ETHERNET Powerlink. The MicroFlex e100 can be controlled over the integrated CANopen port or Ethernet.

CANopen Manager Capability

The Microflex e100 has an integrated CAN port which can be configured to act as a network manager. This provides a convenient and powerful means to expand your system with CANopen digital and analog I/O devices conforming to the CiA DS401 standard. Devices, such as digital and analog input/output modules are managed by the drive, but the I/O states are available to the Mint program running on the NextMove e100, as though local to the motion controller itself.

Integrated Two Port Ethernet Hub

Connecting multiple devices on the Ethernet network is simplified by an integrated 2 port hub. Simply daisy chain the connection to the next device in the system.

Space Vector Modulation Improves Efficiency

By controlling the IGBT power devices using space vector modulation (SVM) instead of the more usual carrier based pulse width modulation (PWM), users can run servo motors at higher speeds without introducing harmonics. In today's world of increased productivity, this can translate directly into greater machine throughput.

Filters Eliminate Resonance

Advanced digital filtering techniques can be applied to reduce the effect of mechanical resonance on system performance.

The drive has two separate digital filters. Each can be adapted to specific frequencies as notch filters, or as low pass filters. Adapting the filters to eliminate or reduce the effects of resonance allow higher system gains and tighter control to be attained. This maximizes machine control bandwidth, without suffering from the increased resonance and performance degradation that would otherwise result.

Configuring these filters is aided by a simple filter design interface which, combined with the Mint WorkBench oscilloscope and FFT (Fast Fourier Transform) analysis, allows the user to test the axis open and closed loop frequency response. The resonant components can then be identified and filter designs tested for effectiveness.

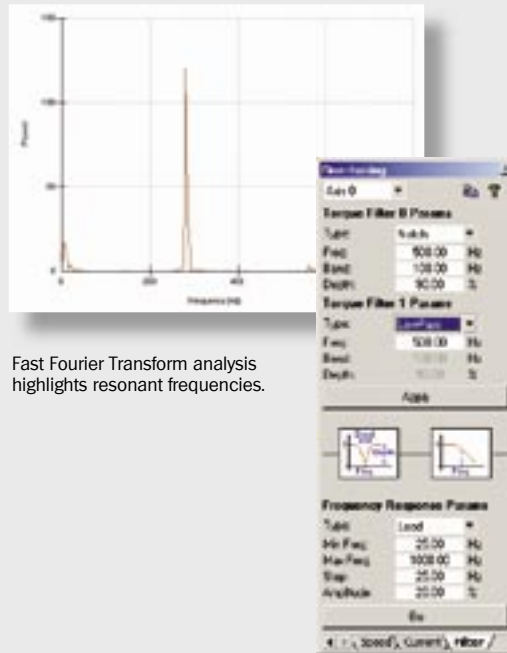

Fast Fourier Transform analysis highlights resonant frequencies.

Mint Workbench digital filter design tool.

Node and IP Address

The drives node ID (address) is set by two rotary hexadecimal switches, a standard feature of Powerlink devices. The IP address is then automatically derived from this, greatly simplifying network configuration.

TCP/IP Communications via ActiveX

In addition to the deterministic mode of ETHERNET Powerlink, the MicroFlex e100 can also be commanded in an *open* mode using TCP/IP messages. This features is supported by Baldor's Mint ActiveX tools, which can provide control of a network of drives from a Windows based PC. In this mode the drive perform simple motion tasks such as point-to-point moves and homing sequences. Interpolated motion across axes is not supported in this mode.

Digital I/O for Axis Functions

Four digital inputs provide typical drive and motion signals such as home sensor limit switches, a hardware enable interlock. Two can be used for high speed registration, capturing position in typically less than 1µS. The outputs can be configured for functions such as motor brake control and drive ready.

This I/O is available to the NextMove e100 motion controller as though the I/O is local to the controller itself. Limit errors, for example, will call the Mint error handler on the NextMove e100. A position latch on the MicroFlex e100 drive will result in the position latch event being called within the Mint program on the NextMove e100. This greatly simplifies system expansion.

Universal Power Supply for a Global Market

MicroFlex operates from a single or three phase supply, 115 to 230 VAC. The control electronics are maintained by an external customer supplied 24 VDC supply, in the event of main AC power removal, for typical safety schemes.

Universal Encoder Interface

A unique interface design provides support for leading encoder technology. Incremental encoders (with or without Hall-effect tracks), EnDat 2.1/2.2, Synchronous Serial Interface (SSI) single or multi-turn absolute encoders and 1V Sin/Cos encoders, are all supported on a single platform. This reduces stocking and spares requirements and also ensures the capability to utilize high performance feedback devices for optimum precision, accuracy and smooth speed regulation.

Auto-tuning Made Easy.

Auto-tuning takes place on the drive itself, adapting the current controller, speed and position loops for the axis. In addition, it verifies feedback device signals and cabling errors. Because the position loop is tuned on the drive, there is no tuning to do on the NextMove e100 motion controller. This further simplifies system tuning and maintenance.

Matched Performance™ Motors

Baldor designs and manufactures both the drives and the rotary and linear motors it controls. We ensure that the motor and drive are matched to operate together with optimal performance, and provide trouble free installation. The Mint Workbench configuration tool has access to all Baldor motor data, simplifying drive configuration.



› Technical Data

Ethernet	Specification: 100Mbit - IEEE802.3u compliant Protocol : ETHERNET Powerlink V2 (EPL) and IP protocols TCP/UDP Interface : Integrated 2 port Hub for daisy chain connection Cable type : CAT5e Shielded cable, RJ45 connectors, Max 100m (330ft) Address: 2 rotary HEX switches sets node and IP address Function : EPL /CiA DS402 Positioning Drive
Communications	ETHERNET Powerlink for real-time control and system networking, USB for configuration CANopen - DS402 Positioning drive profile or drive can manage local CAN DS401 I/O devices for system I/O expansion
Digital Inputs	4 total - opto-isolated 24V, 1mS sample rate including the following functions: 1 reserved for drive hardware enable 2 inputs with high speed position latch - for registration applications. <1µS latency May be connected positive or negative common for use with NPN or PNP signals Software configurable level/edge triggered an application functions e.g. HOME, LIMIT, STOP
Digital Outputs	2 opto-isolated 12-24VDC PNP. 50mA per channel, 350mA max load for single channel, 500mA total for 8 channels Software configured functions including Motor Brake control (requires external relay)
Indicators	1 off LED for drive status/health 2 off LEDs for Ethernet activity 2 off LEDs for CANopen activity
Operating modes	Profiled Torque (current), Profiled Velocity (speed), Profiled Position - including Homing, Incremental absolute moves etc. Interpolated position mode with Mint motion controllers
CANopen	Single CAN port via standard 9 pin Sub-D connector. CANopen DS301: Manager of CANopen DS401 I/O devices, Master functionality for peer-to-peer communications with other Mint nodes CiA DS402 Positioning drive mode via CANopen (controlled device)

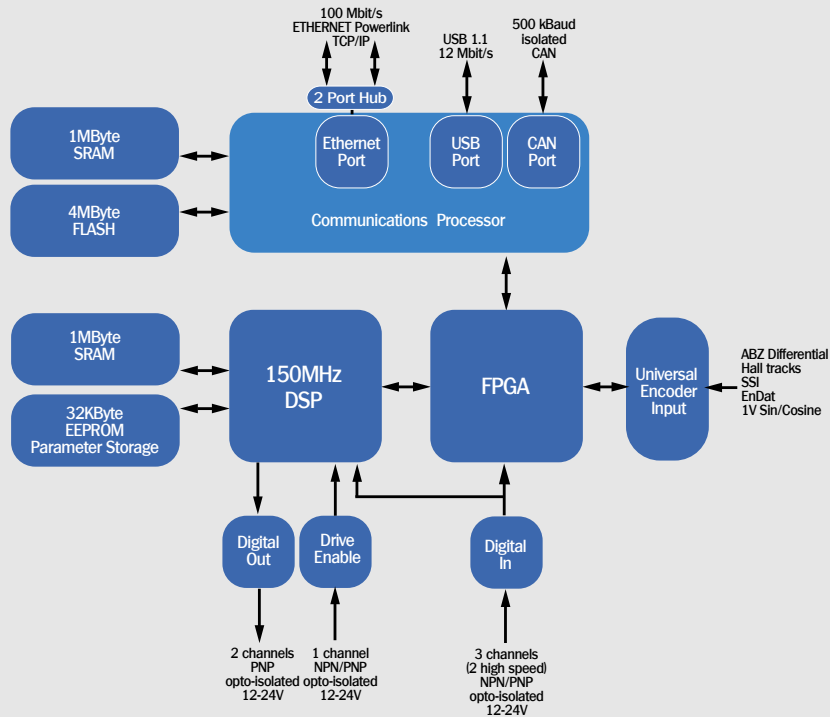

Accessories

A range of accessories for MicroFlex e100 are available to make system integration easier. These include 24V power supplies, pre-made motor and Ethernet cables in different lengths, braking resistors, EMC filters and cooling fans. Full information on these accessories can be found on page 24 and in the Accessories section, BR1202-H.

Ordering Information

Catalog Number	Description
MFE230A003	MicroFlex e100 AC Servo Drive 3 Amp continuous, 105-230VAC 50/60Hz
MFE230A006	MicroFlex e100 AC Servo Drive 6 Amp continuous, 105-230VAC 50/60Hz
MFE230A009	MicroFlex e100 AC Servo Drive 9 Amp continuous, 105-230VAC 50/60Hz

See page 24 for the complete Product Ordering Information.

Type	MFE100-003A230	MFE100-006A230	MFE100-009A230
Power Requirements	1 or 3 Phase 105-230 VAC 50/60Hz		
Current Rating	3 Amp continuous 6 Amp peak (3 Sec)	6 Amp continuous 12 Amp peak (3 Sec)	9 Amp continuous 18 Amp peak (3 Sec)
Regenerative braking	Integrated IGBT output. Requires external resistor		
Control Supply	24 VDC ±10% : Nominal 1 Amp externally supplied to maintain electronics when AC supply is removed. Up to 4 Amp inrush on power up.		
Feedback Devices	Universal Encoder Interface, supporting: - SSI encoders 13-18 bit single and multi-turn - EnDat absolute encoders (v2.1 and v2.2) - Commutating incremental encoders (with Hall effect sensors). 5V differential signals. - Hall sensor only for DC trapezoidal control - 1V Peak - Peak Sin/Cos analog encoders with onboard interpolation		
Protection	DC bus over voltage monitoring; DC bus under voltage monitoring; Peak over-current; Motor short circuit; Over temperature; I2T over current, network failure, etc.		
Dimensions	H: 180 mm (7.09") W: 79.6 mm (3.13") L: 157 mm (6.18")		
Weight	1.5 Kg (3.3 lbs.)		
Environmental limits	Temperature range 0°C to 45°C (32°F to 113°C)		
Approvals	CE, UL, cUL		

› Ordering Information

NextMove e100



Catalog Number	Description
NXE100-1616	NextMove e100 - 16 Axis motion controller: Differential stepper outputs
NXE100-1616S	NextMove e100 - 16 Axis motion controller: Single ended open collector stepper outputs for use with DSM integrated stepper/driver motors

MicroFlex e100



Catalog Number	Description
MFE230A003	MicroFlex e100 AC Servo Drive 3 Amp continuous, 105-230VAC 50/60Hz
MFE230A006	MicroFlex e100 AC Servo Drive 6 Amp continuous, 105-230VAC 50/60Hz
MFE230A009	MicroFlex e100 AC Servo Drive 9 Amp continuous, 105-230VAC 50/60Hz

EMC Filters



Catalog Number	Description
FI0029A00	EMC Footmount Filter (22A) single phase power for all power ratings (2 x 250VAC, 22A)
FI0015A00	EMC Filter for 3A single phase power (2 x 250VAC, 6A)
FI0015A02	EMC Filter for 6A single phase power (2 x 250VAC, 12A)
FI0029A00	EMC Filter for 9A single phase power (2 x 250VAC, 22A)
FI0018A00	EMC Filter for 3A three phase power (3 x 480VAC, 7.7A)
FI0018A00	EMC Filter for 6A three phase power (3 x 480VAC, 7.7A)
FI0018A03	EMC Filter for 9A three phase power (3 x 480VAC, 17.5A)
FI0014A00	EMC Filter for 24V Supply

Braking/Regen Resistors



Catalog Number	Description
RG56	44W regen resistor for use with 3A MicroFlex
RG39	100W regen resistor for use with 6A / 9A MicroFlex

Fan Tray

Provides forced air cooling for MicroFlex e100. Required if average current is above 3A RMS.

Catalog Number	Description
FAN001-024	Fan tray for single MicroFlex



Programmable HMI Panels

Baldor's range of programmable HMI panels offers everything from simple text displays through to large color touch screen panels.

- › Text displays from 4x20 character displays to 8x40 with keyboard entry
- › Touch screen displays from mono 3.8" to color TFT 12.1"

All displays are programmable with an easy to use Windows front end, removing the burden of handling the HMI task from the motion controller. Communications to NextMove is via serial or CANopen communications.

Refer to catalog **BR1202-H** for full information.

Catalog Number	Description
KPD-KG420-20	4x20 character text/graphic display with numerical keypad.
KPD-KG420-30	4x20 character text/graphic display with numerical keypad and additional function keys
KPD-KG840-10	8x40 character text/graphic display with alpha-numerical keypad
KPD-TS03M-10	3.8" mono touch screen
KPD-TS05M-10	5.6" mono touch screen
KPD-TS05C-10	5.6" color (STN) touch screen
KPD-TS10C-10	10.4" color (TFT) touch screen
KPD-TS12C-10	12.1" color (TFT) touch screen
KPD-OPTC	CANopen option card

Mint[®] NC



Catalog Number	Description
MNC001-501	Mint [®] NC – CAD to Motion Windows front end

Refer to catalog **BR1202-B** for full information.



Cables

A range of cables, both pre-made and raw, are available. These include motor power cables, feedback cables and communication cables. Available in different lengths, the pre-made cables are fitted appropriate connectors at both ends, reducing setup time and costs significantly.

Further details can be found in the brochure BR1202-H

Ethernet Cables

Catalog Number	Description
CBL002CM-EXS	200mm (8") CAT5e Shielded RJ45 Ethernet Cable
CBL005CM-EXS	500mm (1.6ft) CAT5e Shielded RJ45 Ethernet Cable
CBL010CM-EXS	1m (3.2ft) CAT5e Shielded RJ45 Ethernet Cable
CBL020CM-EXS	2m (6.5ft) CAT5e Shielded RJ45 Ethernet Cable
CBL050CM-EXS	5m (16.3ft) CAT5e Shielded RJ45 Ethernet Cable
CBL100CM-EXS	10m (32.6ft) CAT5e Shielded RJ45 Ethernet Cable

Series II and MicroFlex* to NextMove e100 Simulated Encoder Cables

Catalog Number	Description
Series II/MicroFlex to NextMove ESB/ES/BX-II/e100	
CBLxxxMF-E3B	Motion feedback cable
	Specify length: 005 (0.5m/1.6ft); 010 (1m/3.2ft); 015 (1.5m/4.8ft); 020 (2m/6.5ft); 030 (3m/9.8ft); 040 (4m/13.1ft); 050 (5m/16.3ft)
*Note these are for the analog Microflex and are not required for e100 version.	



Power Supply Units

Baldor offer a range of 24V power supply units (PSU) that are ideal for powering NextMove motion controllers and the control electronics of the Baldor servo drives. With universal 110-240VAC input, the PSU's are available with current ratings of 3.2A (75W), 5A (120W) and 10A (240W). A 120W unit is capable of powering a single NextMove e100 and three MicroFlex e100 drives.

Catalog Number	Description
DR-75-24	24V Universal Power Supply. 75W/3.2A output
DR-120-24	24V Universal Power Supply. 120W/5.0A output
DRP-240-24	24V Universal Power Supply. 240W/10A output

Refer to catalog BR1202-H for full information.

Servo Drive Solutions

Whether you are looking for a simple servo drive or a fully programmable drive, Baldor has the answer. Baldor servo drives have been at the heart of automation for over 20 years and have been used in thousands of applications across the world. Our latest drives build on the reputation of quality and ease of use and are ideally matched to Baldor's range of NextMove motion controllers, rotary servo motors and linear servo motors. Commissioning and setup use the same acclaimed Mint[®] WorkBench Windows tool as the NextMove controllers, reducing the learning curve and improving productivity.



MicroFlex™

Refer to catalog BR1202-D for full information.

Baldor's MicroFlex is a compact brushless servo drive capable of powering either rotary or linear motors, and is available in single phase 110-230VAC 50/60Hz or 3 phase 230VAC operation in current ratings of 3, 6 and 9 amps. Feedback is software programmable, accepting encoder, SSI (Synchronous Serial Interface) or Hall-effect sensors. Resolver feedback is available as an option. The new MicroFlex e100 offers a fully digital solution utilizing ETHERNET Powerlink to reduce wiring between the drive and motion controller (NextMove e100), increasing reliability and improving set-up



FlexDrive-II, Flex+Drive[®]-II and MintDrive[®]-II

Refer to catalog BR1202-D for full information.

Baldor's Series-II servo drives offer high performance control of both rotary and linear brushless servo motors. This fully featured drive family offer different feedback options (resolver, incremental and absolute multi-turn encoders) and fieldbusses (CANopen, DeviceNet and Profibus-DP). Models are available with single phase 115/230VAC (2.5 to 7.5A) or universal three phase 180-460 VAC (2.5 to 27.5A) inputs.

The FlexDrive-II is a servo drive for connection to a motion controller or PLC accepting the industry standard $\pm 10V$ analog interface. The Flex+Drive-II is a versatile indexing drive. In addition to setting position or speeds within a simple Windows front end, Flex+Drive-II is programmable in a single tasking version of Baldor's motion language, Mint[®]. The MintDrive-II provides the ultimate solution for single axis applications. Support the acclaimed multitasking version of Mint, MintDrive-II is ideally suited for following type applications requiring cam profiles, flying shears or positional offsets.



H2™ Servo Drive

Refer to catalog BR702 for full information.

Baldor's new H2-series incorporates an easy to use keypad for setup, auto-tuning and operation. The keypad's graphical alphanumeric display provides full parameter names to simplify setup and operation, 14 keys provide tactile feel. Includes auto-tuning. Optional field installable expansion boards extend capability to suit application needs Models include internal power supply and are available in three phase ratings from 180-264 VAC (3 to 54A) and three phase 340-528 VAC (3 to 27A). Vector, encoderless vector and inverter drives are also available.



Euroflex

Refer to catalog BR1202-D for full information.

A compact rack mount servo drive, EuroFlex offers the same ease of use and flexibility as the MicroFlex servo drive. With an encoder feedback is suitable for both rotary and linear servo motors, the industry standard $\pm 10V$ command interface makes it compatible with any motion controller or PLC on the market today. EuroFlex's rack mounted format makes it the ideal partner for NextMove ES multi-axis motion controller. EuroFlex is available with a current rating of 5A (15A peak) and 80VDC/56VAC input.

Motor Solutions

For over 20 years, Baldor has been manufacturing and supplying high reliability servo motor solutions to worldwide applications. Baldor's servo motors are designed for industrial applications, superior durability and proven reliability. Our range of rotary motors are available as a high performance, low inertia family, or as a higher inertia family for more cost effective applications. Baldor's new stainless steel motors lead the way in solutions for harsh and washdown environments.

With the widest range of linear motors and stages on the market today, Baldor's linear motors lead the way and are ideally suited to applications requiring higher speeds or improved accuracy.

BSM Series Servo Motors

Refer to catalog BR1202-E for full information.

BSM motors are hard at work, increasing productivity, improving part quality, providing precision and reducing costs in many applications. These motors are available in two models, the BSM N-Series and the BSM C-Series. The N-Series motors provide low inertia for the highest performance. The C-Series motors have a higher inertia, with a cost effective design. All the motors are available with different feedback options including resolver, 2500ppr encoder, SSI (Synchronous Serial Interface) and EnDat. Motors are available from 0.4 Nm (4 lb.-in) through to 40 Nm (354 lb.-in).

Both motor families are available in a stainless steel configuration, offering the best protection for harsh environment. These motors are ideally suited for pharmaceutical and food applications.



Linear Motors and Stages

Refer to catalog BR1202-G for full information.

Used in thousands of applications worldwide, Baldor provides industry with the widest range of linear motors and linear stages. Linear motors provide unique speed and positioning performance advantages. The direct-coupled motion eliminates mechanical transmission devices and offer substantial improvements over applications using ball screws, timing belts, etc. The rugged mechanical design provides accurate motion and precision positioning for millions of cycles.



DSM - Integrated Stepper Motor and Drive

Refer to flyer FL1851 for full information.

Baldor's new DSM integrated stepper motor and microstepping drive provides a cost effective solution for stepper motor applications. The unique design integrates a high performance micro-stepping drive onto a stepper motor, providing a compact and reliable solution. Wiring is reduced to just pulse and direction plus power. The range is available in NEMA frames sizes 17, 23 and 34 with torque outputs from 22 to 748 N-cm (32 to 1061 oz-in)



DC Servo Motors

Refer to catalog BR1202-F for full information.

The Baldor family of DC servo motors (PMDC) provide continuous torques from 0.21Nm to 6.55Nm (1.8 lb.-in to 58 lb.-in.) These high performance motors are designed to meet the demanding requirements of industrial motion control. A wide variety of windings and feedback devices are available for your application needs.



Baldor's Motion Solutions Catalogs

- BR1202-A** Motion Control Solutions
- BR1202-B** Mint[®] Software and Applications
- BR1202-C** NextMove Multi-Axis Motion Controllers
- BR1202-D** AC Servo Drives
- BR1202-E** AC Servo Motors
- BR1202-F** DC Servo Motors and Drives
- BR1202-G** Linear Motors and Stages
- BR1202-H** Motion Product Accessories
- BR1202-I** Real-Time Ethernet Motion Solutions

World Headquarters (U.S.A.)

Baldor Electric Company

Tel: +1 479 646-4711
Fax: +1 479 648-5792
E-mail: sales.us@baldor.com

Australia

Tel: +61 2 9674 5455
Fax: +61 2 9674 2495
E-mail: sales.au@baldor.com

China

Phone: +86-21-64473060
Fax: +86-21-64078620
E-mail: sales.cn@baldor.com

Germany

Tel: +49 89 905 08-0
Fax: +49 89 905 08-490
E-mail: sales.de@baldor.com

India

Tel: +91 20 25 45 95 31/32
Fax: +91 20 25 45 95 30
E-mail: sales.in@baldor.com

Italy

Tel: +41 91 640 9950
Fax: +41 91 630 2633
E-mail: sales.it@baldor.com

Japan

Tel: +81 45-412-4506
Fax: +81 45-412-4507
E-mail: sales.jp@baldor.com

Korea

Tel: +(82-32) 508 3252
Fax: +(82-32) 508 3253
E-mail: sales.kr@baldor.com

Mexico

Tel: +52 477 761 2030
Fax: +52 477 761 2010
E-mail: sales.mx@baldor.com

Singapore

Tel: +65 744 2572
Fax: +65 747 1708
E-mail: sales.sg@baldor.com

Switzerland

Tel: +41 52 647 4700
Fax: +41 52 659 2394
E-mail: sales.ch@baldor.com

United Kingdom

Tel: +44 1454 850000
Fax: +44 1454 859001
E-mail: sales.uk@baldor.com

For additional office locations visit

www.baldor.com

Local Distributor:

Sold by Servo Systems Co.
115 Main Road, P.O. Box 97
Montville, NJ 07045-0097
Toll Free: (800) 922-1103
Phone: (973) 335-1007
Fax: (973) 335-1661
www.servosystems.com