

# AC and DC Gearmotors

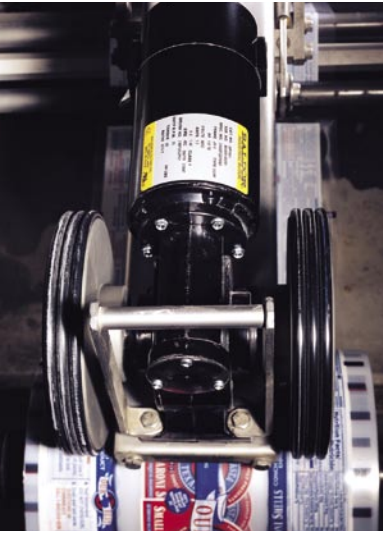

**BALDOR**<sup>®</sup>  
MOTORS • DRIVES • GENERATORS

# BALDOR

MOTORS • DRIVES • GENERATORS

Any product is only as good as its individual components. Starting with careful attention to detail in the engineering stage and continuing through the selection of materials and manufacturing processes, each component is designed to stand up in rugged industrial applications.



Die cast housings are produced in our own facility. Machined on

precision CNC machining centers and checked on state-of-the-art measuring equipment, these housings provide rigid support and accurate alignment of the gears.

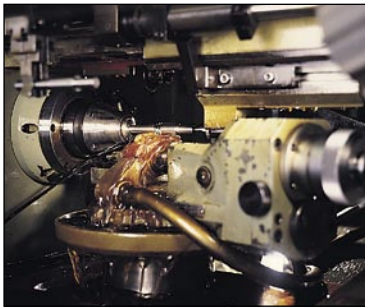

All motors are ball bearing type, rated for industrial duty. These motors, both AC and DC, are constructed from precision machined components and are dynamically balanced for smooth quiet operation.

Outside surfaces are protected by a durable heat cured dry powder coating which is FDA approved for food processing applications.



Continuing education and training helps our people maintain the highest standards of quality. From initial design through final test, our employees are dedicated to building the best product possible.

Over 300 stock ratings are available from Baldor district offices and distributors across the country. Thousands of custom combinations can be assembled from a wide range of standard ratios, motors, and mountings. Baldor sales and engineering personnel are available to help solve your application problems.



## Other Gear Solutions from Baldor

### Worm Gear Reducers



### Stainless Steel Worm Gear Reducers



### Helical Worm



### In-Line Helical Gear Units



### Ratio Multipliers



### Gearmotors



### Inverter Duty Gearmotors



# RIGHT ANGLE GEARMOTORS FEATURES AND BENEFITS

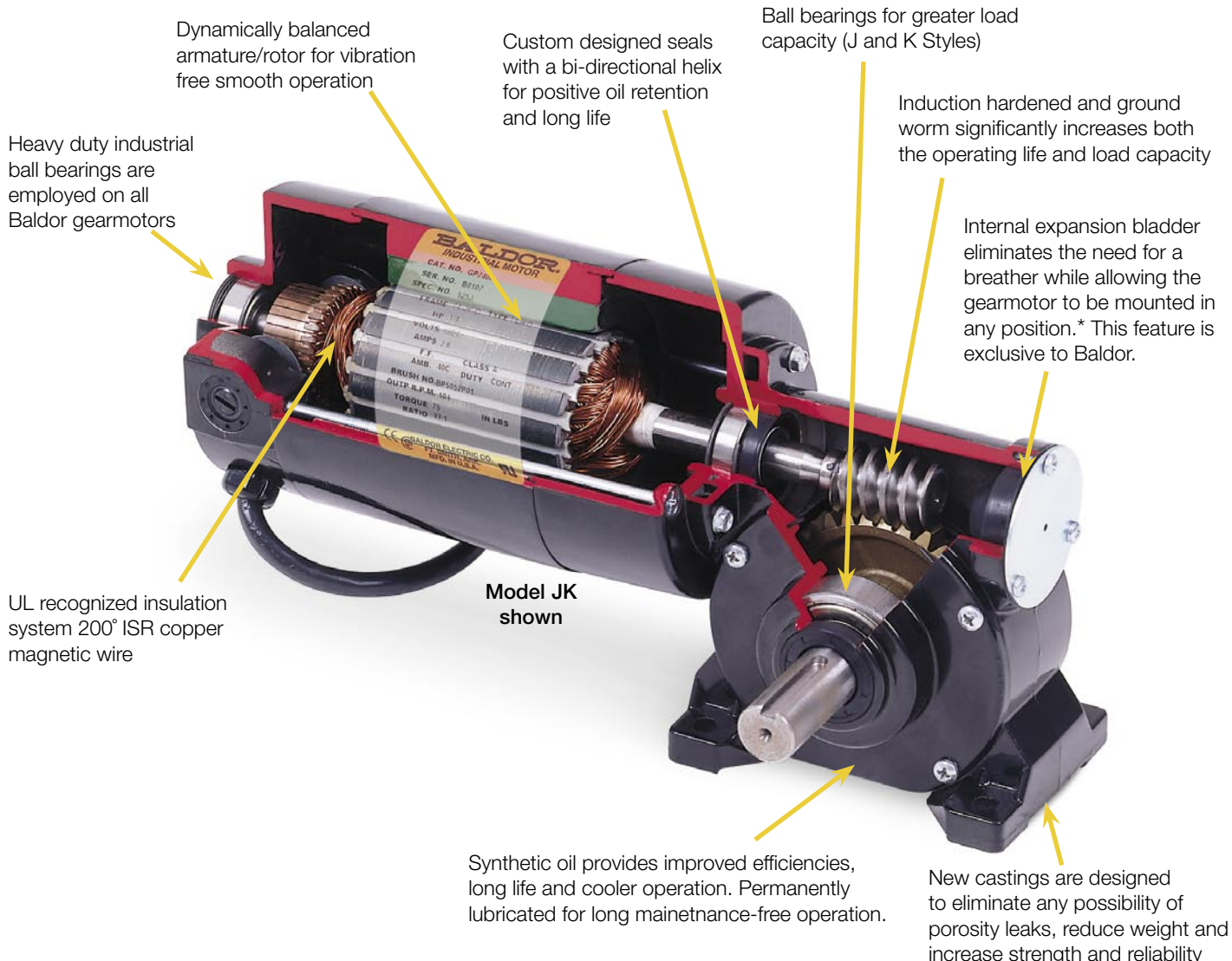

\* Vertical motor below gearhead not recommended.

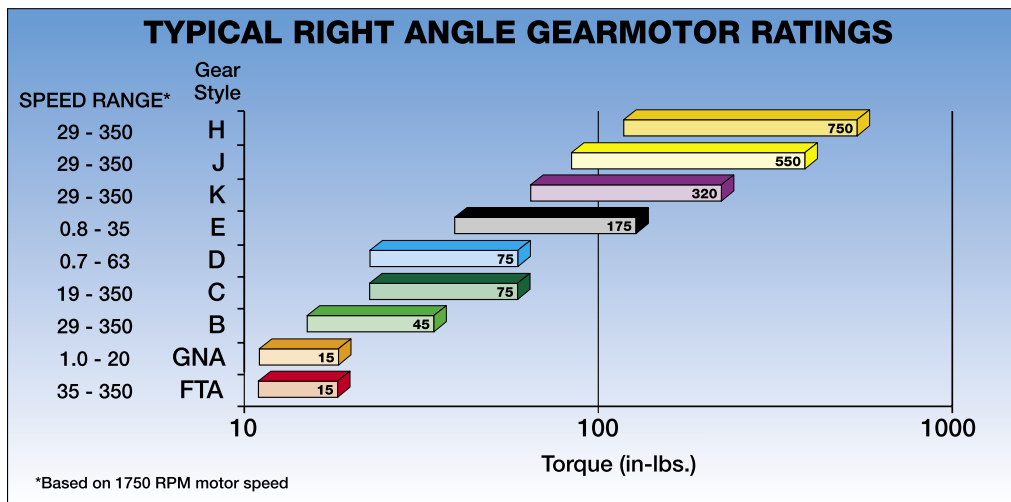

## SINGLE REDUCTION WORM GEARMOTORS



**Style FTA**

- Hardened and ground steel worm provides quiet operation and long life
- Factory lubricated for life, no routine maintenance is required
- Double 5/16" output shafts provides mounting flexibility
- AC & DC ratings up to 1/20 hp
- Torque ratings to 15 in-lbs
- Available in 90 volts DC & 115 volts AC



**Style B**

- Hardened and ground steel worm provides quiet operation and long life
- Factory lubricated for life with Mobil SHC 634 synthetic oil
- Baldor's exclusive internal oil expansion bladder. Keeps lubrication in and contamination out
- Double 1/2" output shafts provides mounting flexibility
- AC & DC ratings up to 1/6 hp
- Torque ratings to 45 in-lbs
- Available in DC voltages 90 or 180 and AC voltages 115 or 230/460



**Style C**

- Hardened and ground steel worm provides quiet operation and long life
- Factory lubricated for life with Mobil SHC 634 synthetic oil
- Baldor's exclusive internal oil expansion bladder. Keeps lubrication in and contamination out
- Double 1/2" output shafts provides mounting flexibility
- AC & DC ratings up to 1/4 hp
- Torque ratings to 75 in-lbs
- Available in DC voltages 90 or 180 and AC voltages 115 or 230/460



**Style K**

- Hardened and ground steel worm provides quiet operation and long life
- Factory lubricated for life with Mobil SHC 634 synthetic oil
- Baldor's exclusive internal oil expansion bladder. Keeps lubrication in and contamination out
- Single 5/8" output shaft has both keyway and flat
- AC & DC ratings up to 1/2 hp
- Torque ratings to 320 in-lbs
- Available in DC voltages 90 or 180 and AC voltages 115 or 230/460



**Style J**

- Hardened and ground steel worm provides quiet operation and long life
- Factory lubricated for life with Mobil SHC 634 synthetic oil
- Baldor's exclusive internal oil expansion bladder. Keeps lubrication in and contamination out
- Double 3/4" output shafts provides mounting flexibility
- AC & DC ratings up to 1/2 hp
- Torque ratings to 550 in-lbs
- Available in DC voltages 90 or 180 and AC voltages 115 or 230/460

**NOTE:** Vertical motor below gearhead not recommended. Avoiding those positions where the high speed oil seal is immersed in oil, will provide greater security against high speed input seal wear.



**Style H**

- Hardened and ground steel worm provides quiet operation and long life
- Ratios sfrom 5:1 to 60:1
- Factory lubricated for life with Klubersynth UH1-6-460 USDA food grade oil
- Baldor's exclusive internal oil expansion bladder, keeps oil in and contamination out
- Symmetrical, 1.00" hollow through-bore design
- AC & DC ratings up to 1 hp
- Torque ratings to 550 in-lbs

## DOUBLE REDUCTION WORM GEARMOTORS



**Style GNA**

- Hardened and ground steel worms provides quiet operation and long life
- Ratios from 88:1 to 1600:1
- Double 5/16" output shafts provides mounting flexibility
- AC & DC ratings up to 1/50 hp
- Torque ratings to 15 in-lbs
- Available in DC voltages 90 or 180 and AC voltages 115 or 230/460



**Style D**

- Hardened and ground steel worms provides quiet operation and long life
- Ratios from 27.4:1 to 2500:1
- Factory lubricated for life with Mobil SHC 634 synthetic oil
- Baldor's exclusive internal oil expansion bladder. Keeps lubrication in and contamination out
- Double 1/2" output shafts provides mounting flexibility
- AC & DC ratings up to 1/20 hp
- Torque ratings to 75 in-lbs
- Available in DC voltages 90 or 180 and AC voltages 115 or 230/460



**Style E**

- Hardened and ground steel worms provides quiet operation and long life
- Ratios from 50:1 to 2000:1
- Factory lubricated for life with Mobil SHC 634 synthetic oil
- Baldor's exclusive internal oil expansion bladder. Keeps lubrication in and contamination out
- Double 5/8" output shafts provides mounting flexibility
- AC & DC ratings up to 1/4 hp
- Torque ratings to 175 in-lbs
- Available in DC voltages 90 or 180 and AC voltages 115 or 230/460

**NOTE:** Vertical motor below gearhead not recommended. Avoiding those positions where the high speed oil seal is immersed in oil, will provide greater security against high speed input seal wear.

## PARALLEL SHAFT GEARMOTORS

Heavy duty industrial ball bearings are employed on all Baldor gearmotors

Dynamically balanced armature/rotor for vibration free smooth operation

Custom designed seals with a bi-directional helix for positive oil retention and long life



UL recognized insulation system 200° ISR copper magnetic wire

Model PSL shown

Extra wide Helical\* gearing (PSL and PSLH) greatly improves load capacity and quiet operation

Heavy duty industrial ball bearing on interim stages on all parallel gearmotors

All parallel shaft gearmotors are permanently lubricated for life with synthetic lubrication for long maintenance-free operation.

New castings are designed to eliminate any possibility of porosity leaks, reduce weight and increase strength and reliability

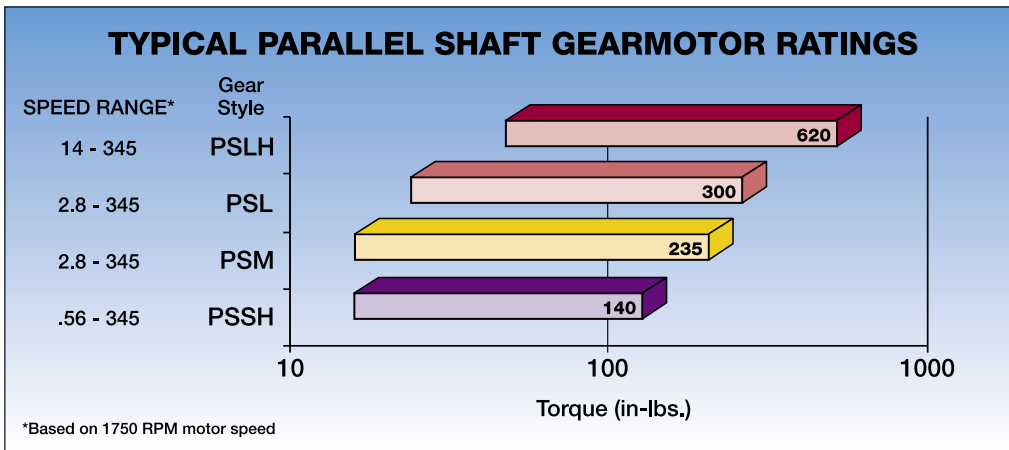

## PARALLEL SHAFT GEARMOTORS



**Style PSSH**

- Induction hardened helical and spur gears for extra strength
- Ball and needle bearing construction for improved torque capacity
- Factory lubricated for life with Mobil SHC 634 synthetic oil
- Output shaft is 1/2" diameter
- Industry standard mounting dimensions
- AC & DC ratings up to 1/4 hp
- Ratios from 5:1 to 3125:1
- Torque ratings to 144 in-lbs
- Available in DC voltages 90 or 180 and AC voltages 115 or 230/460
- Additional bases for greater mounting flexibility available



**Style PSM**

- Induction hardened helical and spur gears for extra strength
- Ball and needle bearing construction for improved torque capacity
- Factory lubricated for life with synthetic Mobilith SHC 007
- Output shaft is 5/8" diameter
- Industry standard mounting dimensions
- AC & DC ratings up to 1/8 hp
- Ratios from 5:1 to 625:1
- Torque ratings to 235 in-lbs
- Available in DC voltages 90 or 180 and AC voltages 115 or 230/460
- Additional bases for greater mounting flexibility available



**Style PSL**

**Style PSLH**

- Induction hardened helical gears for extra strength
- Ball and needle bearing construction for improved torque capacity
- Factory lubricated for life with synthetic Mobilith SHC 007
- Output shaft is 3/4" diameter
- Industry standard mounting dimensions
- AC & DC ratings up to 1/2 hp
- Ratios from 5:1 to 625:1
- Torque ratings to 637 in-lbs
- Available in DC voltages 90 or 180 and AC voltages 115 or 230/460
- Additional bases for greater mounting flexibility available

**NOTE:** Vertical motor below gearhead not recommended. Avoiding those positions where the high speed oil seal is immersed in oil, will provide greater security against high speed input seal wear.

## GEARMOTOR ACCESSORIES



**BKP2400 Conduit Box**

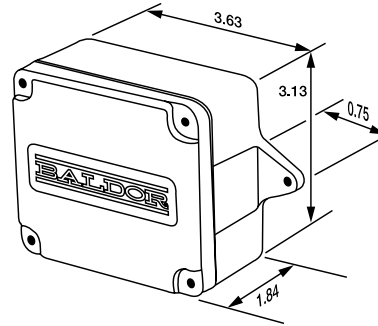

BKP2400 is an optional combination conduit/capacitor mounting kit. This box may be use with stock 24 frame AC motors and Gearmotors.



**B92 Base**

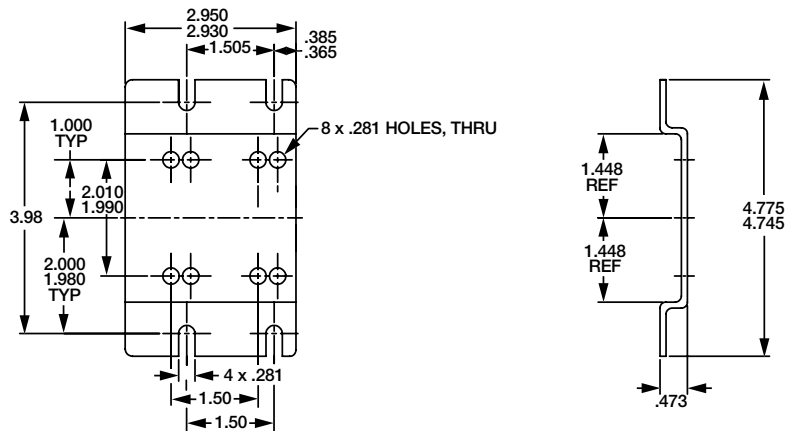

B92 is a formed steel-mounting base that bolts to the bottom of the PSM gearbox casting. Provides secure foot mounting and drop-in interchangeability with other manufacturers.



**B93 Adapter**

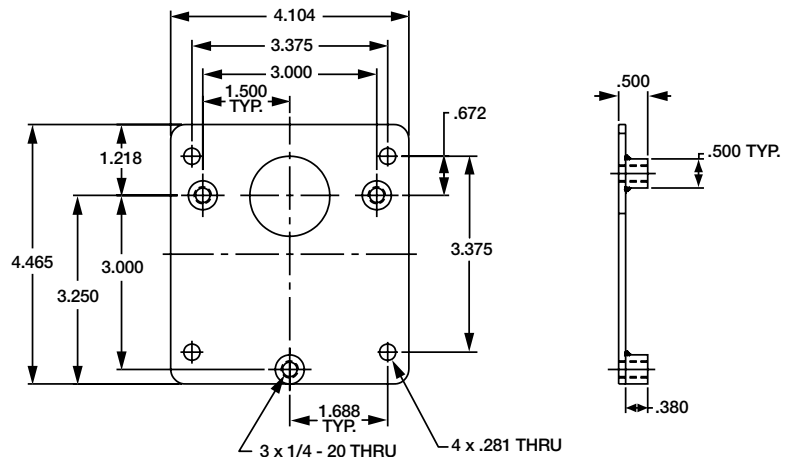

B93 is a three point face mounting adapter. Provides Interchangeability with other manufactures. Baldor also can provide a PSM with the three point mount integral to the gearhead casting. Contact your local Baldor sales office for additional information.

## GEARMOTOR ACCESSORIES



**LB73 & LB73GR** are “L” type mounting brackets used with the PSSH gearmotor. Securely mounts to gear face in a 90 degree locations for floor, wall or ceiling mount. **LB73** is painted black to match stock DC motor while **LB73GR** is painted gray to match our AC line.

**LB74** “L” type mounting brackets used with the PSL and PSLH gearmotor. Securely mounts to gear face in a 90 degree locations for floor, wall or ceiling mount. **LB74** is not recommended for units weighing over 20 lbs.

**LB75** “L” type mounting brackets used with the PSL and PSLH gearmotor. Securely mounts to gear face in a 90 degree locations for floor, wall or ceiling mount. **LB75** is recommended for units weighing over 20 lbs.

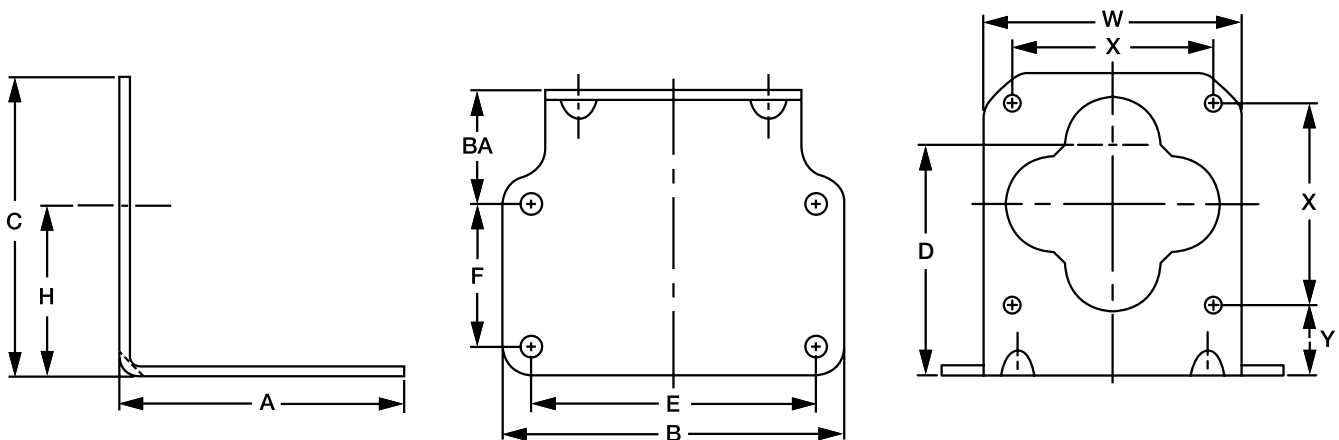

	A	B	C	D	E	F	H	BA	W	X	Y
LB73	3.75	4.50	3.94	3.03	3.75	1.88	2.25	1.50	3.40	2.65	0.93
LB74	4.50	6.00	5.45	4.00	5.00	2.50	3.10	1.50	4.63	3.62	1.28
LB75	6.00	6.00	6.00	4.00	5.00	2.50	3.10	1.50	6.00	3.62	1.28

## NEMA Enclosed DC Controls FOR PERMANENT MAGNET OR SHUNT WOUND MOTORS



BC140 Enclosed  
(NEMA 1)

Features common to enclosed and chassis mount controls:

- Full wave SCR control with free wheeling diode (NEMA type K) except regen controls.
- Field power supply allows use with shunt wound DC motors as well as permanent magnet motors.
- Adjustable accel, decel, current limit, IR comp, min. and max. speed. Current limit indicating LED.
- 5K speed pot for speed control (remote on chassis mount).
- Kit available for forward/brake/reverse switching (BC140, BC154, BC254 only).
- Horsepower resistor and armature fuse selectable to match control and motor for each application. (Included in price of control).
- Customer selectable armature or tach feedback (except BC138, BC139, BC140, BC140-FBR).
- Anti-demag circuit protects PM motors and helps protect the SCR power bridge against direct shorts.
- Noise rejection circuit eliminates false starts and blown SCR's.
- US and Canadian UL component recognition.

Additional features are standard only on enclosed control:

- On-off switch
- Pilot light
- Terminal strip connections
- 115/230 voltage selection switch or jumper (BC140, BC140-FBR, BC200, BC201, BC202, BC203, BC204, BC254 and BC354 only)
- Built in armature and line fusing
- BC140-FBR includes Forward-Brake-Reverse switch

A Plug-in Horsepower Resistor® and armature fuse **must** be ordered and installed in BC138, BC139, BC140, BC140-FBR, BC141 and BC142. Spare resistor kits are also available. Resistor should be selected based on the motor's rated current.

Hp Range	Catalog Number	Approximate Shipping Weight (Lbs)	Input Voltage
1/100-1/3	BC138	1	115 VAC
1/50-3/4	BC139	1	230 VAC
1/100-2*	BC140	3	115/230 VAC
1/100-2*	BC140-FBR	3	115/230 VAC

**NOTE:** \*1 Hp at 115V and 2 Hp at 230V requires BC143 heatsink kit.  
FBR = Forward/Brake/Reverse.

## DC Control Accessories

Catalog Number	Description	Approximate Shipping Weight (Lbs)
BC24-LF	Ac Line Filter for use with CE Applications	0.5
BC143	External Heatsink Kit (BC140, BC140-FBR, BC141, BC142)	2.0
BC144	Forward-Brake-Reverse Switch Kit for BC140	0.4
BC145	Signal Isolator Board	0.5
BC146	Current Sensing Relay/Overload Protector	0.4
BC147	Barrier Terminal Board (BC141 & BC142)	0.3
BC148	Replacement Potentiometer Kit (5K ohm)	0.1
BC149	Knob and Dial Kit	0.1
BC151	Electronic Speed Potentiometer	0.5
BC152	Barrier Terminal Board With Signal Isolator (BC141 AND BC142)	1.0
BC218	DIN-rail mounting kit for BC141, BC142 or BC204	0.5

**NOTE:** BC24-LF is an AC line filter required for applications where CE is required if the control is not filtered elsewhere in the application. This filter is used on most 115 or 230 VAC, single phase applications where CE is required.

## Chassis Mount DC Controls



BC141 / BC142



BC155

Hp Range	Catalog Number	Approximate Shipping Weight (Lbs)	Input Voltage (1Ph,50/60 Hz)
1/100-1.5**	BC141	1	115 VAC
1/50-3**	BC142	2	230 VAC
5	BC155	5	230 VAC

**NOTE:** Above controls include 5k speed potentiometer.

\*\*1-1.5 Hp at 115 Volts and 2-3 Hp at 230 Volts, requires BC143 Heatsink kit. BC155 Includes integral heatsink.

## Plug-In Horsepower Resistor & Fuse Kit

A Plug-in Horsepower Resistor® and armature fuse **must** be ordered and installed in BC138, BC139, BC140, BC140-FBR, BC141 and BC142. These should be selected based on the motor's **rated current**.

Motor Hp Armature Voltage		Plug-In Hp Resistor Resistance Value (OHms)	Baldor Catalog Number	Approximate Motor Current (DC Amps)	DC Fuse Rating (AC Amps)
90-130 VDC	180 VDC				
1/100	1/50	1.00	BR1000	0.20	0.50
1/50	1/25	0.51	BR0510	0.30	0.50
1/30	1/15	0.35	BR0350	0.33	0.50
1/20	1/10	0.25	BR0250	0.50	0.75
1/15	1/8	0.25	BR0251	0.80	1.00
1/12	1/6	0.18	BR0180	0.85	1.25
1/8	1/4	0.10	BR0100	1.30	2.00
1/6	1/3	0.10	BR0101	2.00	2.50
1/4	1/2	0.05	BR0050	2.50	4.00
1/3	3/4	0.035	BR0035	3.30	5.00
1/2	1	0.025	BR0025	5.00	8.00
3/4	1 1/2	0.015	BR0015	7.50	12.00
1*	2*	0.01	BR0010	10.00	15.00
1 1/2*	3*	0.006	BR0006	15.00	25.00**

**NOTE:** \* External Heatsink required. \*\* Also used with AC Line Fuse. For AC line fuse rating see manual.

## Fractional Horsepower DC Speed Controls FOR PERMANENT MAGNET MOTORS



- Variable Transformer for Manual Speed Adjustment
- Heavy Duty Silicon Full Wave Rectifier
- Built-In Circuit Breaker
- Center Lock Reversing Switch (Center Off)
- Pilot Light
- On/Off Switch
- Totally-Enclosed Cabinet (NEMA 1)
- Supplied w/Type SJO Oil Resistant Cord, 7 Feet Long
- Input Voltage 115VAC 1 $\phi$ ; Output Voltage 0-90 VDC
- CSA Listed File # LR54532

Maximum Hp	Catalog Number	Approximate Shipping Weight (Lbs)	Amp Capacity	Input Voltage
1/15	BC110	5	1.0	115 VAC
1/8	BC115	6	1.5	115 VAC
1/4	BC130	10	3.0	115 VAC

**Contact your nearest Baldor District Office at these  
World Wide locations, or visit [www.baldor.com](http://www.baldor.com)**

**UNITED STATES**

**ARIZONA  
PHOENIX**

4211 S 43RD PLACE  
PHOENIX, AZ 85040  
PHONE: 602-470-0407  
FAX: 602-470-0464

**CALIFORNIA  
LOS ANGELES**

6480 FLOTILLA  
COMMERCE, CA 90040  
PHONE: 323-724-6771  
FAX: 323-721-5859

**HAYWARD**

21056 FORBES STREET  
HAYWARD, CA 94545  
PHONE: 510-785-9900  
FAX: 510-785-9910

**COLORADO  
DENVER**

2520 W BARBERRY PLACE  
DENVER, CO 80204  
PHONE: 303-623-0127  
FAX: 303-595-3772

**CONNECTICUT  
WALLINGFORD**

65 SOUTH TURNPIKE ROAD  
WALLINGFORD, CT 06492  
PHONE: 203-269-1354  
FAX: 203-269-5485

**FLORIDA  
TAMPA/PUERTO RICO/  
VIRGIN ISLANDS**

3906 EAST 11TH AVENUE  
TAMPA, FL 33605  
PHONE: 813-248-5078  
FAX: 813-247-2984

**GEORGIA  
ATLANTA**

62 TECHNOLOGY DR.  
ALPHARETTA, GA 30005  
PHONE: 770-772-7000  
FAX: 770-772-7200

**ILLINOIS  
CHICAGO**

1601 FRONTENAC ROAD  
NAPERVILLE, IL 60563  
PHONE: 630-848-5100  
FAX: 630-848-5110

**INDIANA  
INDIANAPOLIS**

5525 W. MINNESOTA STREET  
INDIANAPOLIS, IN 46241  
PHONE: 317-246-5100  
FAX: 317-246-5110  
800-428-4141

**IOWA  
DES MOINES**

1800 DIXON STREET, SUITE C  
DES MOINES, IA 50316  
PHONE: 515-263-6929  
FAX: 515-263-6515

**MARYLAND  
BALTIMORE**

6660 SANTA BARBARA RD.  
SUITE 22-24  
ELKRIDGE, MD 21075  
PHONE: 410-579-2135  
FAX: 410-579-2677

**MASSACHUSETTS  
BOSTON**

6 PULLMAN STREET  
WORCESTER, MA 01606  
PHONE: 508-854-0708  
FAX: 508-854-0291

**MICHIGAN  
DETROIT**

33782 STERLING PONDS  
BLVD.  
STERLING HEIGHTS,  
MI 48312  
PHONE: 586-978-9800  
FAX: 586-978-9969

**GRAND RAPIDS**

668 3 MILE ROAD NW  
GRAND RAPIDS, MI 49504  
PHONE: 616-785-1784  
FAX: 616-785-1788

**MINNESOTA  
MINNEAPOLIS**

21080 134TH AVE. NORTH  
ROGERS, MN 55374  
PHONE: 763-428-3633  
FAX: 763-428-4551

**MISSOURI  
ST LOUIS**

422 INDUSTRIAL DRIVE  
MARYLAND HEIGHTS,  
MO 63043  
PHONE: 314-298-1800  
FAX: 314-298-7660

**KANSAS CITY**

915 N W PLATTE VALLEY DR  
RIVERSIDE, MO 64150  
PHONE: 816-587-0272  
FAX: 816-587-3735

**NEW YORK  
AUBURN**

ONE ELLIS DRIVE  
AUBURN, NY 13021  
PHONE: 315-255-3403  
FAX: 315-253-9923

**NORTH CAROLINA  
GREENSBORO**

1220 ROTHERWOOD ROAD  
GREENSBORO, NC 27406  
P O BOX 16500  
GREENSBORO, NC 27416  
PHONE: 336-272-6104  
FAX: 336-273-6628

**OHIO  
CINCINNATI**

2929 CRESCENTVILLE ROAD  
WEST CHESTER, OH 45069  
PHONE: 513-771-2600  
FAX: 513-772-2219

**CLEVELAND**

8929 FREEWAY DRIVE  
MACEDONIA, OH 44056  
PHONE: 330-468-4777  
FAX: 330-468-4778

**OKLAHOMA  
TULSA**

2 EAST DAWES  
BIXBY, OK 74008  
PHONE: 918-366-9320  
FAX: 918-366-9338

**OREGON  
PORTLAND**

20393 SW AVERY COURT  
TUALATIN, OR 97062  
PHONE: 503-691-9010  
FAX: 503-691-9012

**PENNSYLVANIA  
PHILADELPHIA**

1035 THOMAS BUSCH  
MEMORIAL HIGHWAY  
PENNSAUKEN, NJ 08110  
PHONE: 856-661-1442  
FAX: 856-663-6363

**PITTSBURGH**

616H BEATTY ROAD  
MONROEVILLE, PA 15146  
PHONE: 412-380-7244  
FAX: 412-380-7250

**TENNESSEE  
MEMPHIS**

4000 WINCHESTER ROAD  
MEMPHIS, TN 38118  
PHONE: 901-365-2020  
FAX: 901-365-3914

**TEXAS  
HOUSTON**

4647 PINE TIMBERS  
SUITE # 135  
HOUSTON, TX 77041  
PHONE: 713-895-7062  
FAX: 713-690-4540

**DALLAS**

3040 QUEBEC  
DALLAS, TX 75247  
PHONE: 214-634-7271  
FAX: 214-634-8874

**UTAH  
SALT LAKE CITY**

2230 SOUTH MAIN STREET  
SALT LAKE CITY, UT 84115  
PHONE: 801-832-0127  
FAX: 801-832-8911

**WISCONSIN  
MILWAUKEE**

2725 SOUTH 163RD STREET  
NEW BERLIN, WI 53151  
PHONE: 262-784-5940  
FAX: 262-784-1215

**INTERNATIONAL SALES  
FORT SMITH, AR**

P.O. BOX 2400  
FORT SMITH, AR 72902  
PHONE: 479-646-4711  
FAX: 479-648-5895

**CANADA  
EDMONTON, ALBERTA**

4053-92 STREET  
EDMONTON, ALBERTA  
T6E 6R8  
PHONE: 780-434-4900  
FAX: 780-438-2600

**OAKVILLE, ONTARIO**

2750 COVENTRY ROAD  
OAKVILLE, ONTARIO L6H 6R1  
PHONE: 905-829-3301  
FAX: 905-829-3302

**MONTREAL, QUEBEC**

1844 WILLIAM STREET  
MONTREAL, QUEBEC  
H3J 1R5  
PHONE: 514-933-2711  
FAX: 514-933-8639

**VANCOUVER,  
BRITISH COLUMBIA**

1538 KEBET WAY  
PORT COQUITLAM, BC  
V3C 5M5  
PHONE 604-421-2822  
FAX: 604-421-3113

**WINNIPEG, MANITOBA**

54 PRINCESS STREET  
WINNIPEG, MANITOBA  
R3B 1K2  
PHONE: 204-942-5205  
FAX: 204-956-4251

**AUSTRALIA**

UNIT 3, 6 STANTON ROAD  
SEVEN HILLS, NSW 2147,  
AUSTRALIA  
PHONE: (61) (2) 9674 5455  
FAX: (61) (2) 9674 2495

**UNIT 8, 5 KELLETTS ROAD  
ROWVILLE, VICTORIA, 3178  
AUSTRALIA**

PHONE: (61) (3) 9753 4355  
FAX: (61) (3) 9753 4366

**BALDOR CENTROAMERICA**

RESIDENCIAL PINARES  
DE SUIZA  
POL. 15 #44, NVA.  
SAN SALVADOR  
EL SALVADOR,  
CENTRO AMERICA  
PHONE: (503) 288-1519  
FAX: (503) 288-1518

**BALDOR SUDAMERICA**

CALLE F. EL CANGREJO  
CONDOMINIO P.H. CONDADO  
PLAZA  
APT. 11D, BELLA VISTA  
PANAMÁ CITY, REP.  
DE PANAMÁ  
PHONE: (507) 265-6041

**CHINA**

SHANGHAI JIAHUA  
BUSINESS CENTER  
ROOM NO. A-8421  
808 HONG QIAO ROAD  
SHANGHAI 200030  
PHONE: 86-21-64473060  
FAX: 86-21-64078620

**GERMANY**

DIESELSTRASSE 22  
D-85551 KIRCHHEIM  
MUNICH, GERMANY  
PHONE: (49) (89) 90508 - 0  
FAX: (49) (89) 90508 - 492

**INDIA**

14, COMMERCE AVENUE  
MAHAGANESH COLONY  
PAUD ROAD  
PUNE - 411 038  
MAHARASHTRA, INDIA  
PHONE: 91 20 25 45 95 31/32  
FAX: 91 20 24 55 95 30

**ITALY**

BALDOR ASR AG  
SUCCURSALE DI MENDRISIO  
VIA BORROMINI, 20A  
CH-6850 MENDRISIO  
SWITZERLAND  
PHONE: 41 91 640 9952  
FAX: 41 91 630 2633

**JAPAN**

DIA BLDG 802,  
2-21-1 TSURUYA-CHO,  
KANAGAWA-KU  
YOKOHAMA, 221-0835,  
JAPAN  
PHONE: 81-45-412-4506  
FAX: 81-45-412-4507

**KOREA**

ROOM 210  
BUPYEONG INDUSTRIAL  
COMMERCIAL COOPERATIVE  
396-16 CHEONGCHEON  
2-DONG,  
BUPYEONG-GU  
INCHEON, KOREA, 403-858  
PHONE: 82 32 508 3252  
FAX: 82 32 508 3253

**MÉXICO**

KM. 2.0 BLVD. AL  
AEROPUERTO  
LEÓN 37545, GUANAJUATO,  
MÉXICO  
PHONE: 52 477 761 2030  
FAX: 52 477 761 2010

**MIDDLE EAST & NORTH  
AFRICA**

VSE INTERNATIONAL CORP.  
3233 NORTH ARLINGTON  
HEIGHTS  
SUITE 100W  
ARLINGTON HEIGHTS,  
IL 60004  
PHONE: 847 590 5547

**SINGAPORE**

51 KAKI BUKIT ROAD 2  
K B WAREHOUSE COMPLEX  
SINGAPORE 417863  
PHONE: (65) 6 744 2572  
FAX: (65) 6 747 1708

**SWITZERLAND**

POSTFACH 73  
SCHUTZENSTRASSE 59  
CH-8245 FEUERTHALEN  
SWITZERLAND  
PHONE: (41) (52) 6474700  
FAX: (41) (52) 6592394

**TAIWAN**

4F, NO. 25, SEC. 1  
TUNHUA S ROAD  
TAIPEI 10657, TAIWAN, R.O.C.  
PHONE: (886-2) 2577-4352  
FAX: (886-2) 2577-4157

**UNITED KINGDOM**

6 BRISTOL DISTRIBUTION  
PARK  
HAWKLEY DRIVE  
BRISTOL BS32 0BF U.K.  
PHONE: 44 1454 850000  
FAX: 44 1454 859001



**Baldor Electric Company**  
P.O. Box 2400  
Fort Smith, AR 72902-2400 U.S.A.  
Ph (479) 646-4711 • Fax (479) 648-5792  
International Fax (479) 648-5895  
[www.baldor.com](http://www.baldor.com)

