

Sold by Servo Systems Co. 115 Main Road, P.O. Box 97, Montville, NJ 07045-0097  
Toll Free: (800) 922-1103 Phone: (973) 335-1007 Fax: (973) 335-1661  
www.servosystems.com

MODEL	POWER	I-CONT	I-PEAK
412CE	24-90 VDC	10	20
413CE	24-90 VDC	15	30
421CE	24-180 VDC	5	10
422CE	24-180 VDC	10	20

## FEATURES

- **CE Compliance to 89/336/EEC**
- **Recognized Component to UL 508C**
- **Flexibility!** Internal 40-pin socket configures amp with no soldering
- **Separate current limits:** Continuous, peak, and peak-time
- **No integrator windup** when disabled
- **3 LED's for faster setup:** Normal/enable, power-OK, Fault (short or overtemp)
- **Fault protections:** Short-circuits from output to output, output to ground, Over/under voltage, Over temperature, Self-reset or latch-off modes
- **3kHz Bandwidth**
- **Wide load inductance range: 0.2-40 mH.**
- **Surface mount technology construction, lower part count.**

## APPLICATIONS

- X-Y stages
- Robotics
- Automated assembly machinery
- Automatically guided vehicles
- Magnetic bearings

## THE OEM ADVANTAGE

- **Conservative design for high MTBF**
- **No soldering required to change header parts.**
- **Custom configurations available (contact factory) No-pots, custom head**
- **Underwriters Laboratories**



## FEATURES

These amplifiers are variants of the popular 4xx series DC brush motor amplifiers that feature compliance with European Community directive 89/336/EEC, also known as "CE".

The 400 series are third-generation amplifiers for dc brush motors from Copley Controls Corp. Models operate from +24 to +225VDC unregulated power supplies, and output peak currents from 10 to 30A.

Built using surface-mount technology, these amplifiers offer a full complement of features for servo motor control. All models take industry standard  $\pm 10V$  control signals as input, and operate motors in three different modes: torque, velocity, and voltage feedback with IR compensation.

Torque-mode finds the widest application for motors used with digital control cards that take encoder feedback from the motor for velocity and position control.

Velocity loops using brush-tachometer feedback are used for open-loop speed controls, or in position control loops requiring superior regulation at low speeds.

Tachless speed controls can be made using output voltage feedback with IR compensation where lowest cost is required. Active logic-level of Enable, Pos Enable, and Neg Enable inputs is switch-selectable to interface with all types of control cards.

Ground-to-enable or ground-to-inhibit are both supported.

Mosfet H-bridge output stage delivers power in four-quadrants for bi-directional acceleration and deceleration of motors.

An internal 40-pin header socket holds components that configure the various gain and current limit settings to customize the amplifiers for a wide range of loads and applications.

Individual peak and continuous current limits allow high acceleration without sacrificing protection against continuous overloads. Peak current time limit is settable to match amplifier to motor thermal or commutation limits.

Header components permit compensation over a wide range of load inductances to maximize bandwidth with different motors.

All models are protected against output short circuits ( output to output and output to ground ) and heatplate overtemperature.

With the /Reset input open, output shorts or heatplate overtemperature will latch off the amplifier until power is cycled off & on, or until the /Reset input is grounded. For self-reset from such conditions, wire /Reset to ground and the amplifier will reset every 50ms.

Three status led's speed diagnostics during set-up, or for fault isolation after the unit is in service

# Models 412CE, 413CE, 421CE, 422CE, DC Brush Servo Amplifiers

## TECHNICAL SPECIFICATIONS

Test conditions: 25°C ambient, Load = 200µH in series with 1 Ω., +HV = maximum normal value

MODEL	412	413	421	422
<b>OUTPUT POWER</b>				
Peak power	±20A @ ±80V	±30A @ ±80V	±10A @ ±170V	±20A @ ±170V
Peak time	1 sec at peak power or 2 secs. after polarity reversal			
Continuous power	±10A @ ±80V	±15A @ ±80V	±5A @ ±170V	±10A @ ±170V
<b>OUTPUT VOLTAGE</b>				
	Ro = 0.2	Ro = 0.15	±Vout = ±HV*(0.97) - (Ro)*(Io) Ro = 0.4	Ro = 0.2
<b>LOAD INDUCTANCE</b>				
Selectable with components on header socket: 200 µH to 40mH				
<b>BANDWIDTH</b>				
(Small signal, -3dB, freq)	Current mode: Voltage-feedback mode:	3kHz with 200µH load at maximum supply voltage, varies with load inductance and RH20, CH18 values 200Hz max.		
<b>PWM SWITCHING FREQUENCY</b>				
25kHz				
<b>REFERENCE INPUT</b>				
Differential, 100K between inputs, ±20V maximum				
<b>GAINS</b>				
Input differential amplifier	X1 (Volt / Volt)			
PWM transconductance stage	Ipeak / 6V ( I peak = peak rated output current; 6V measured at Current Ref J2-9 or Current Monitor J2-8 )			
<b>LOGIC INPUTS</b>				
Input voltage range	0 to +24V			
Logic threshold voltage ( LO to HI transition )	2.5V ( Schmitt trigger inputs with hysteresis )			
/Enable ( S1 off; S1 on reverses logic )	LO enables amplifier, HI disables (50ms delay to enable, <1ms to disable)			
/POS enable, /NEG enable ( S1 off; S1 on reverses logic )	LO enables POSitive/NEGative output currents, HI inhibits (<1ms delay)			
/Reset	LO resets latching fault condition, ground for self-reset every 50 ms.			
Input resistance	10K pull-up to +5V, R-C filters to internal logic			
<b>DIP SWITCHES</b>				
S1: Enab LO/HI	S1 OFF: ground enables, open or +5V inhibits (/Enable, /Pos & /Neg enable) S1 ON : open or +5V enables, ground inhibits (/Enable, /Pos & /Neg enable)			
S2: Integrator ON/OFF	S2 ON: torque mode ( integrator off, flat-gain ), OFF: velocity mode ( integrator on, tachometer mode )			
<b>POTS</b>				
Ref Gain	Attenuates Ref input from x1 to 0; controls overall amplifier gain ( amps / volt, rpm / volt, or volts / volt )			
Tach Gain	Tach feedback gain: sets basic rpm / volt ratio; also used as IR comp feedback control			
Loop Gain	Servo preamp DC gain: increases amps / volt gain in torque mode; controls bandwidth in velocity mode			
Integ Freq	Integrator frequency control: not used in torque mode; controls stiffness and speed stability in velocity mode			
Balance/Test	Use to set output current or rpm to zero. RH9 = 10 MΩ for Balance function, RH9 = 100kΩ for Test function			
<b>LOGIC OUTPUTS</b>				
+Fault ( /Normal )	HI = Overtemp OR output short OR power NOT-OK, OR NOT-Enabled; LO = Operating normally AND enabled;			
HI output voltage	2.4V min at -5.2 mA max., <b>+5V maximum</b>			
LO output voltage	0.5V max at 5.2 mA max.			
<b>INDICATORS (LED's)</b>				
Normal	Green: ON = Amplifier Enabled AND Normal ( power OK, no output shorts, no overtemp )			
Power OK	Green: ON = Power OK ( +HV >22V AND ( +HV <92V for 41x, <185V for 42x, <230V for 432 ) )			
Fault	Red: ON = Output short-circuit or over-temperature condition			
<b>MONITOR OUTPUTS</b>				
Current Monitor ( motor or load current )	±6V @ ±Ipeak (1kΩ, 33nF R-C filter)			
Current Ref ( current demand signal to pwm stage )	±6V @ demands ±Ipeak			
Voltage Monitor ( load voltage at output terminals )	Vout / 10 (412, 413), Vout / 20 (421, 422, 423, 432), Bandwidth = 200 Hz			
<b>DC POWER OUTPUTS</b>				
±5VDC @ ±5 mA				
<b>PROTECTIVE FEATURES</b>				
Output short circuit (output to output, output to ground)	Latches unit OFF**			
Overtemperature	Latches unit OFF at 70°C on heatplate **			
Undervoltage shutdown @	<22V	<22V	<22V	<22V
Overvoltage shutdown @	>92V	>92V	>185V	>185V
** Latching faults will self-reset when power is cycled off/on and every 50mS if /Reset input is wired to ground				
<b>POWER REQUIREMENTS</b>				
DC power (+HV)	24-90VDC (412, 413), 24-180VDC (421, 422, 423), 24-225VDC ( 432 ) Transformer isolated from power mains			
Watts minimum	2.5W	2.7W	2.5W	3W
Watts @ Icont	25W	41W	20W	54W
<b>THERMAL REQUIREMENTS</b>				
Storage temperature range: -30 to +85°C; operating temperature range: 0 to 70°C baseplate temperature				
Thermal resistance ( baseplate to ambient ): 2.7°C/W (no heatsink, no fan), 1.6°C/W (heatsink no fan), 1°C/W (no heatsink + fan), 0.4°C/W (heatsink + fan)				
Notes: 1. Heatsink optional ( add "H" to model number ) 2. Fan = forced air over unit @ 400 linear feet/minute				
<b>MECHANICAL</b>				
Amplifier case size	3.28 x 5.09 x 1.43 in. (83.3 x 129.3 x 36.3 mm.)			
Heatsink	Adds 1.50 in. ( 38.1 mm ) to amplifier 1.43 in. dimension. Same length as amp.			
Weight	0.59 lb (0.27 kg.) for amplifier alone; heatsink adds 0.78 lb. (0.35 kg)			
<b>CONNECTORS</b>				
J1 (Power & motor): 5 position compression-connector; Phoenix MKDS 3; maximum wire gauge AWG 12 ( 4 mm <sup>2</sup> solid or 2.5 mm <sup>2</sup> stranded ) wire.				
J2 (Signal): Molex: 22-01-3167 housing with 08-50-0114 pins (16 required)				

COMPONENT HEADER

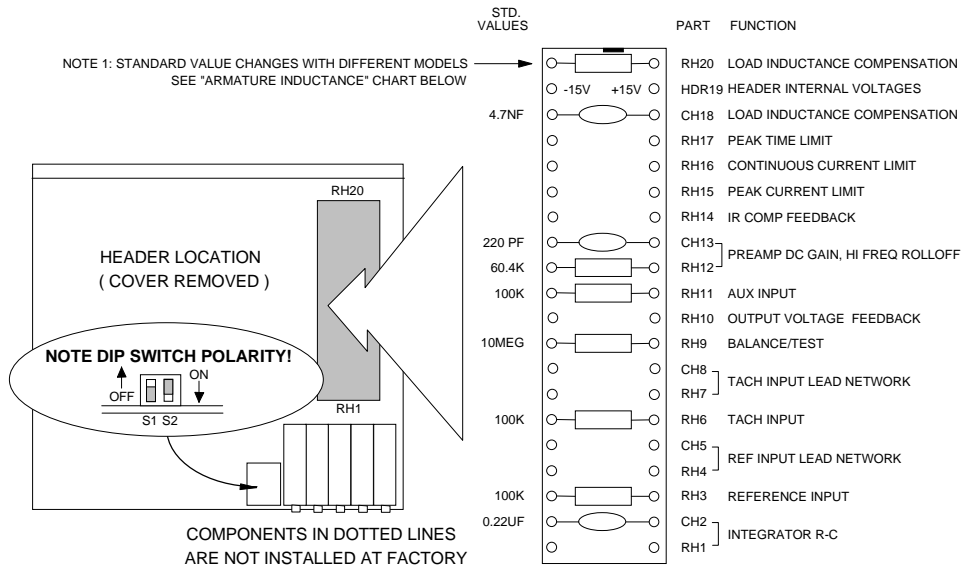

ARMATURE INDUCTANCE (CH18 & RH20):

Model	412		413		421		422		423		432	
	C	R	C	R	C	R	C	R	C	R	C	R
Load (mH)												
0.2 to 0.5		10k		33k		10k		10k		10k		10k
<b>0.6 to 1.9</b>	<b>4.7</b>	<b>49.9k</b>	<b>4.7</b>	<b>80.6k</b>	<b>4.7</b>	<b>15.0k</b>	<b>4.7</b>	<b>24.9k</b>	<b>4.7</b>	<b>46.4k</b>	<b>4.7</b>	<b>40.2k</b>
2 to 5.9		150k		100k		30k		62k		100k		82k
6 to 19		330k		220k		62k		150k		200k	1.5	150k
20 to 40		470k		470k		150k		270k		470k	1	300k

Note: Values in **bold & italics** are factory installed standard. C = CH18 capacitance in nF, R = RH20 resistance in  $\Omega$ . Values shown are for 90V (412, 413), 180V (421, 422, 423), and 225V (432). At lower supply voltages RH20 may be increased and CH18 decreased. To customize values: short CH18, select RH20 for best step response in current-mode, next select CH18 for lowest value that does not degrade step response.

PEAK CURRENT LIMIT

I <sub>peak</sub> (%)	RH15 ( $\Omega$ )
<b>100</b>	<b>open<sup>1</sup></b>
80	68k $\Omega$
60	33k $\Omega$
40	15k $\Omega$
20	6.2k $\Omega$

CONTINUOUS CURRENT LIMIT

I <sub>cont</sub> (%)	RH16 ( $\Omega$ )
<b>100</b>	<b>open<sup>1</sup></b>
80	100k $\Omega$
60	39k $\Omega$
40	15k $\Omega$
20	1k

PEAK CURRENT TIME-LIMIT

T <sub>peak</sub> (s)	RH17 ( $\Omega$ )
<b>1</b>	<b>open<sup>1</sup></b>
0.8	10 Meg $\Omega$
0.6	2.2 Meg $\Omega$
0.4	1 Meg $\Omega$
0.2	330k $\Omega$

Times shown are for 100% step from 0A

Notes on Current Limits:

1. Values in **bold & italics** are factory installed standard.
2. Peak times double after polarity reversal.
3. Peak current limit should be set greater than continuous current limit. If I<sub>peak</sub> < I<sub>cont</sub> then peak overrides continuous limit and I<sub>cont</sub> = I<sub>peak</sub>. Minimum setting for peak current is 0% Minimum setting for continuous current is 16%. with RH16 = 0  $\Omega$ .
4. Continuous current sense is for average current. Symmetrical waveforms with zero average value may cause overtemperature shutdown of amplifier or motor damage due to high I<sup>2</sup>R losses.

# Models 412CE, 413CE, 421CE, 422CE, DC Brush Servo Amplifiers

## FUNCTIONAL DIAGRAM

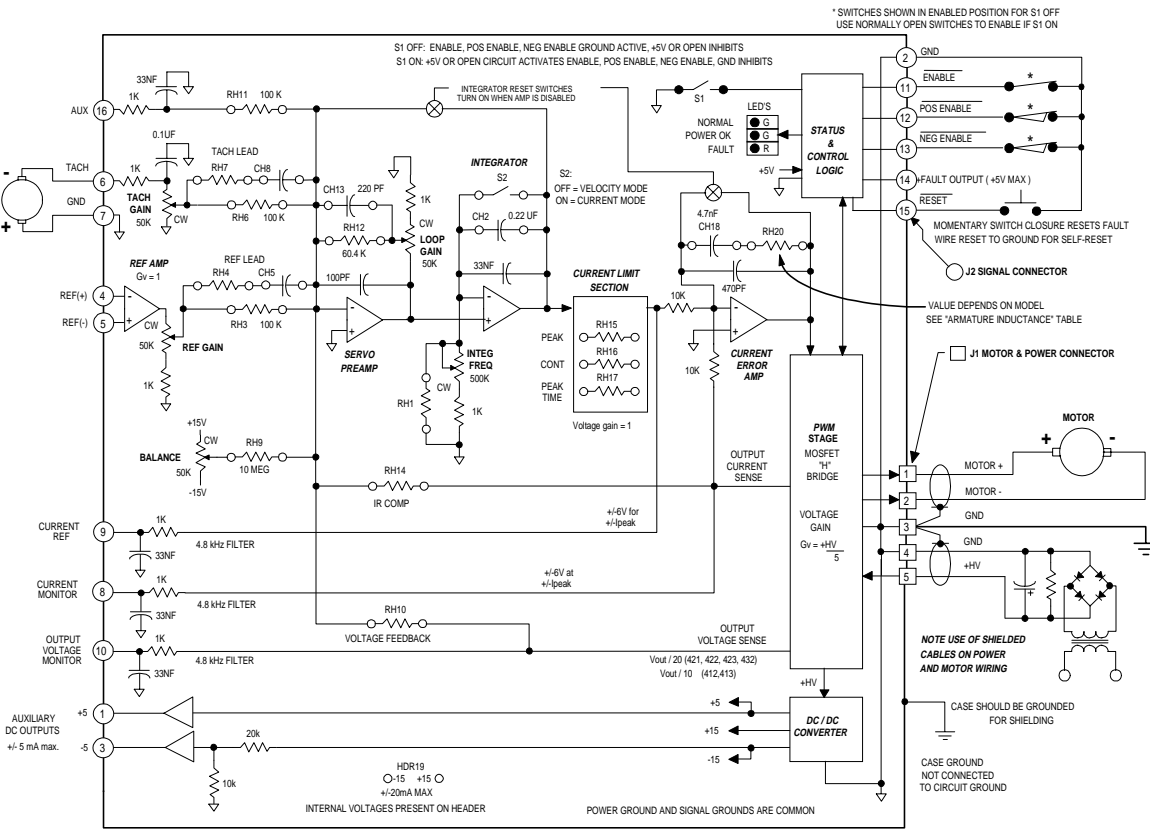

## OUTLINE DIMENSIONS

Dimensions in inches (mm.)

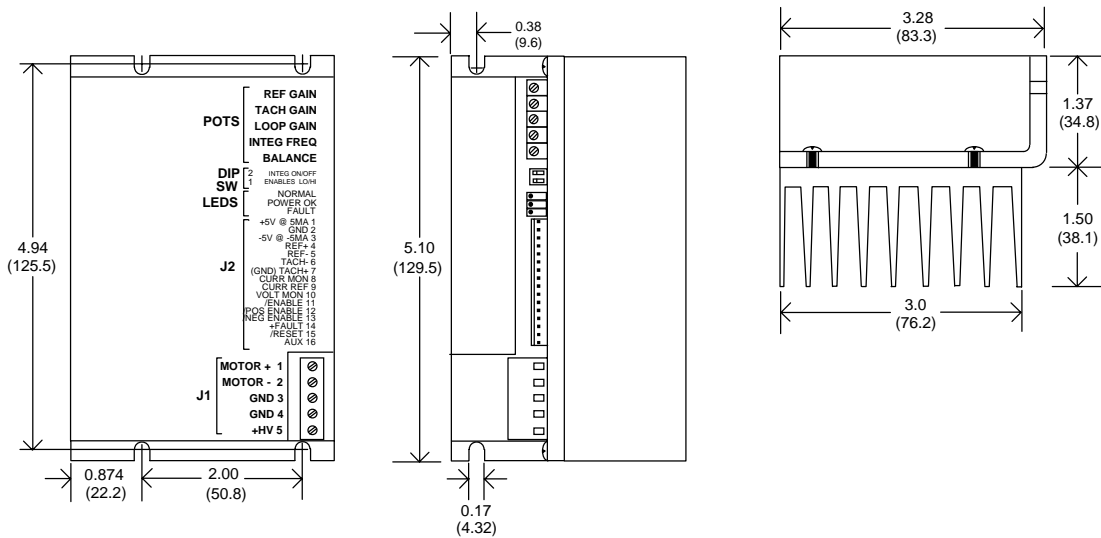

**APPLICATION INFORMATION**

**IMPORTANT! ALWAYS REMOVE POWER WHEN CHANGING  
HEADER PARTS!!**

**SETUP SEQUENCE**

- 1) Set RH15, RH16, and RH17 for motor current-limits to protect motor during setup. Disconnect motor and monitor Curr Ref signal at J2-9 while making settings.
- 2) Set CH18, RH20 on header for armature inductance.
- 3) Connect enable inputs. Set S1 for your enable signal polarity.
- 4) Connect motor and ( if used ) tachometer.
- 5) Connect amplifier to transformer-isolated DC power supply.
- 6) Adjust pots and switch S2 according to operating mode.

**PEAK CURRENT LIMIT**

Amplifiers are shipped with no part installed in RH15. This delivers the amplifiers peak rated current. For lower settings use values from the table.

**CONTINUOUS CURRENT LIMIT**

Choose RH16 based on the motor manufacturers specification for your motor. Table values give basic settings. This setting keeps the motor within its thermal limits. Note that this limit measures average current and will not work on symmetrical waveforms such as might occur during system oscillation. Use an external thermal circuit breaker for protection from such overcurrent faults.

**PEAK-TIME LIMIT**

Header component RH17 controls the length of time for which the amplifier will output peak current. When peak currents that are less than the amplifiers peak rated current, this time will increase, eventually becoming infinite as you reach the continuous current. After a polarity reversal, the peak time will be twice that of a unipolar current change.

**GROUNDING & POWER SUPPLIES**

Connect positive terminal of power supply to J1-5, negative terminal to J1-4. For best results do not ground power supply, but ground each amplifier with heavy wire from J1-3 to equipment 'star' ground point. If power supply is >1m. from amplifiers, add local filter capacitor near amplifiers (250µF minimum per amplifier).

**ENABLE INPUTS**

With S1 OFF, *all* Enable inputs must be *grounded* for the amplifier to operate. For operation with cards that output +5V to *enable* the amplifier, turn S1 ON. Enable active level is now reversed so that grounding inputs will inhibit and +5V (or open) will enable. S1 flips polarity of *all* enable inputs.

*Note: There is a 50ms delay /between Enable TRUE and amplifier ON. Delay on /Pos and /Neg enables is <1ms.*

**ARMATURE INDUCTANCE**

Values from table work well for most applications. To optimize compensation with custom values:

- 1) Turn S2 ON. Disconnect tachometer if used. Set Ref Gain pot fully CW, Loop Gain pot fully CCW.
- 2) Replace CH18 with a jumper (short).
- 3) Apply 20Hz square wave input to Vref. Adjust for ±0.25V at Curr Mon (J2-8).

- 4) Choose value for RH20 that gives best step response without oscillation.
- 5) Replace CH18 with 4.7nF.
- 6) If waveform shows >10% overshoot, try larger capacitor until overshoot is 10% or less. If no change is seen, try smaller value for CH18 until overshoot appears.

**REFERENCE INPUTS**

Connect *both* Ref inputs to control card: Ref(+) to card output, Ref(-) to card ground. Using both inputs will reject ground noise between control card and amplifier. Use shielded, twisted-pair cable to minimize noise pickup between amplifier and controller.

**TORQUE MODE**

For transconductance:  
( Iout / Vref ) = Ipeak / 10V:

- 1) Set S2 ON
- 2) Set Ref Gain fully CW
- 3) Set Loop Gain fully CCW.
- 4) To increase gain, turn Loop Gain CW. To decrease gain, turn Ref Gain CCW.

**VELOCITY MODE  
WITH BRUSH TACHOMETER**

*Disconnect motor from machinery during setup! Tachometer reversal will cause uncontrolled run-away!*  
Set Tach Gain, Loop Gain and Integ. Freq. pots fully CCW.

- 1) Set S2 ON. Connect motor and tach and DC power, enable amplifier and spin shaft. If motor runs away, reverse tachometer connections.
- 2) Apply 5Hz square wave to Ref inputs. Adjust for ±0.25V at Tach input ( J2-6 ).
- 3) Adjust Loop Gain pot CW until oscillation begins, then back-off 2 turns. If oscillation cannot be eliminated, reduce RH12 until adjustment is possible.
- 4) Set S2 OFF. Turn Integ Freq CW until overshoot exceeds 10%, or oscillation begins. Back off for best step response. If overshoot is excessive with pot CCW, change CH2 to 0.47µF and retry. Use value of CH2 that gives good adjustment range for Integ Freq pot.
- 5) Adjust Tach Gain pot for desired Vtach / Vref ratio. Repeat steps 2-4.

Ref Gain pot will reduce Vtach / Vref ratio without affecting tuning. If oscillation occurs when motor is connected to load, repeat steps 2-4.

**VOLTAGE FEEDBACK & IR COMP**

Voltage mode with no IR comp is used with position loops that have no "D" term, or that output a position error signal only. IR comp is used mostly with open-loop speed control systems.

- 1) (Skip this step if no IR comp.) Jumper J2-6 to J2-8. Tach Gain pot now functions as IR comp adjustment (full CW = no IR comp).
- 2) Select RH10. For 41x amplifiers RH10 = HV ( kΩ ). For 42x, and 43x models, RH10 = HV/2 ( kΩ ). Use exact or next larger value.
- 3) Set S2 OFF, Ref Gain, Integ Freq & Tach Gain pots fully CW, Loop Gain pot fully CCW.
- 4) Connect oscilloscope to J2-10, Output Voltage monitor.

# Models 412CE, 413CE, 421CE, 422CE, DC Brush Servo Amplifiers

- 5) Apply  $\pm 1V$ , 10Hz square wave to Ref inputs. Check for oscillation. If oscillation occurs, decrease RH12 to 10k $\Omega$ . Oscillation should now be gone.
- 6) (Skip this step for no IR comp.). Turn Tach Gain pot CCW to increase IR compensation. Too much will cause oscillation. Adjust for best speed regulation under different load conditions. If Tach Gain pot cannot produce oscillation, decrease RH6 until full range is possible.

## APPLICATIONS

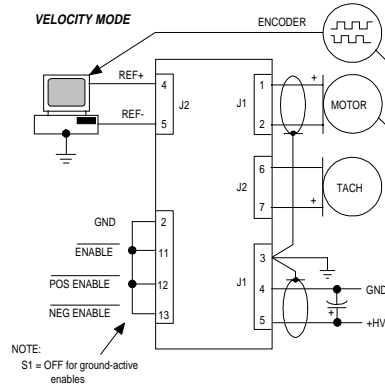
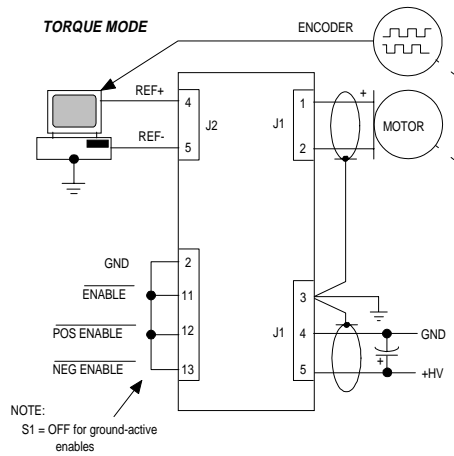

### VOLTAGE FEEDBACK with IR COMP

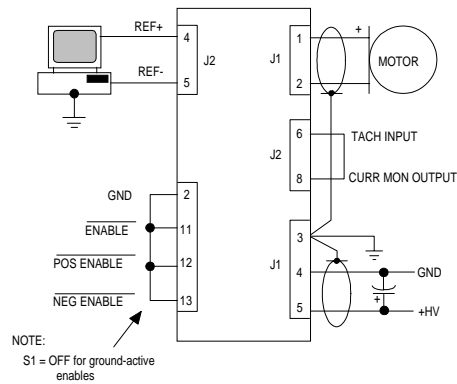

### Notes

1. All amplifier grounds are common (J1-3,4 & J2-2,7)  
Case/heatplate is isolated from amplifier circuits.
2. For ground-active enable inputs, set S1 OFF  
For +5V active enables, set S2 ON ( open inputs will enable amplifier via internal pullups to +5V).
3. For best noise immunity, use twisted shielded pair cable for reference and tachometer inputs.
4. For EMI reduction and CE compliance, use shielded cable for motor and DC power.

## ORDERING GUIDE

Model 412CE	20A peak, 10A continuous, 24-90 VDC brush motor amplifier
Model 413CE	30A peak, 15A continuous, 24-90 VDC brush motor amplifier
Model 421CE	10A peak, 5A continuous, 24-180 VDC brush motor amplifier
Model 422CE	20A peak, 10A continuous, 24-180 VDC brush motor amplifier

- Notes: 1. Add "H" to model number to specify heatsink option.  
2. For "no-pots" or custom component configurations, contact factory