

Sold by Servo Systems Co. 115 Main Road, P.O. Box 97, Montville, NJ 07045-0097
Toll Free: (800) 922-1103 Phone: (973) 335-1007 Fax: (973) 335-1661
www.servosystems.com

FEATURES

- **CE Compliance to 89/336/EEC**
- **Recognized Component to UL 508C**
- **Complete torque (current) mode functional block**
- **Drives motor with 60° or 120° Halls**
- **Single supply voltage 18-55VDC**
- **5A continuous, 10A peak more than double the power output of servo chip sets**
- **Fault protected**
Short-circuits from output to output, output to ground
Over/under voltage
Over temperature
Self-reset or latch-off
- **2.5kHz bandwidth**
- **Wide load inductance range 0.2 to 40 mH.**
- **+5, +15V Hall power**
- **Separate continuous, peak, and peak-time current limits**
- **Surface mount technology**

APPLICATIONS

- **X-Y stages**
- **Robotics**
- **Automated assembly machinery**
- **Component insertion machines**

THE *OEM* ADVANTAGE

- **NO POTS: Internal component header configures amplifier for applications**
- **Conservative design for high MTBF**
- **Low cost solution for small brushless motors to 1/3 HP**



PRODUCT DESCRIPTION

Model 503 is a complete pwm servoamplifier for applications using DC brushless motors in torque (current) mode. It provides six-step commutation of three-phase DC brushless motors using 60° or 120° Hall sensors on the motor, and provides a full complement of features for motor control. These include remote inhibit/enable, directional enable inputs for connection to limit switches, and protection for both motor and amplifier.

The /Enable input has selectable active level (+5V or gnd) to interface with most control cards.

/Pos and /Neg enable inputs use fail-safe (ground to enable) logic. Power delivery is four-quadrant for bi-directional acceleration and deceleration of motors.

Model 503 features 500W peak power output in a compact package using surface mount technology.

An internal header socket holds components which configure the various gain and current limit settings to customize the 503 for different loads and applications.

Separate peak and continuous current limits allow high acceleration without sacrificing protection against continuous overloads. Peak current time limit is settable to match amplifier to motor thermal limits.

Header components permit compensation over a wide range of load inductances to maximize bandwidth with different motors.

Package design places all connectors along one edge for easy connection and adjustment while minimizing footprint inside enclosures.

High quality components and conservative ratings insure long service life and high reliability in industrial installations.

A differential amplifier buffers the reference voltage input to reject common-mode noise resulting from potential differences between controller and amplifier grounds.

Output short circuits and heatplate overtemperature cause the amplifier to latch into shutdown. Grounding the reset input will enable an auto-reset from such conditions when this feature is desired.

Model 503 DC Brushless Servo Amplifier

FUNCTIONAL DIAGRAM

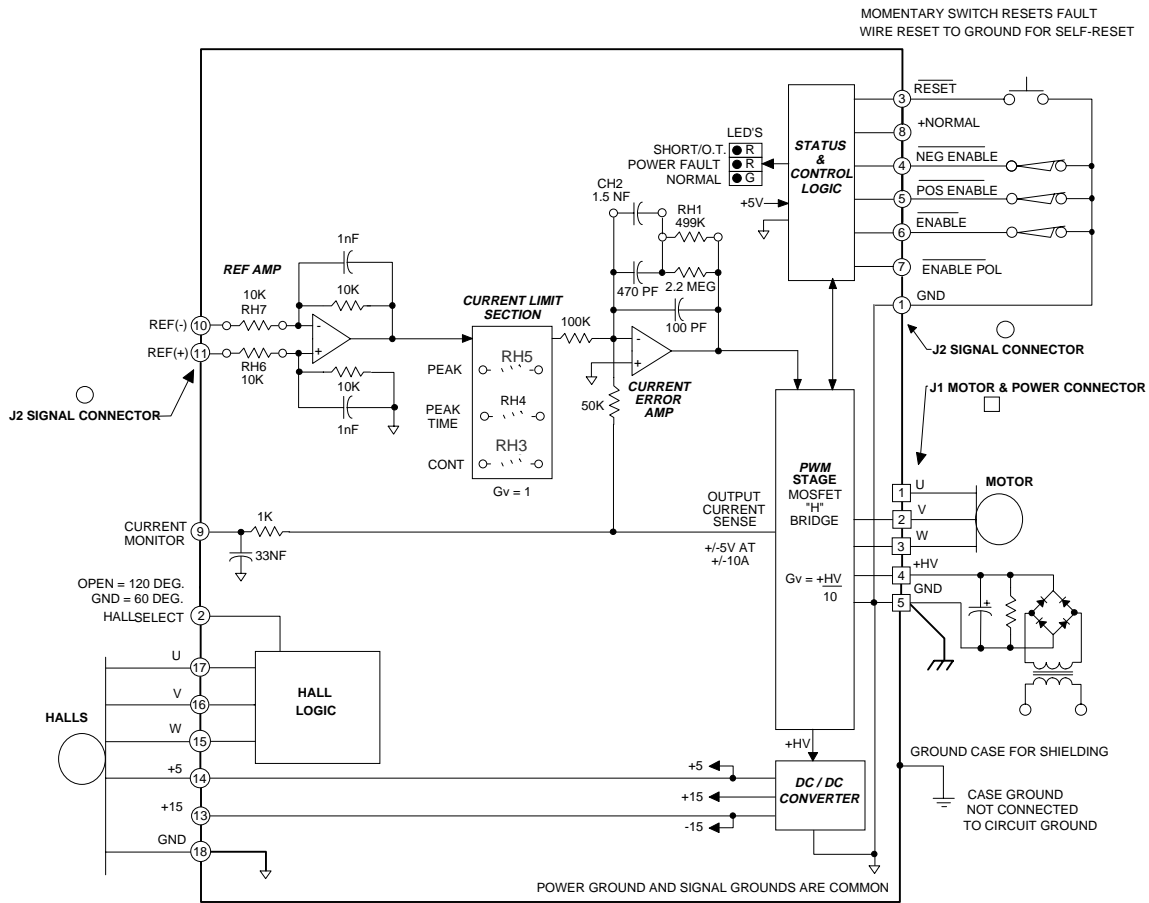

TYPICAL CONNECTIONS

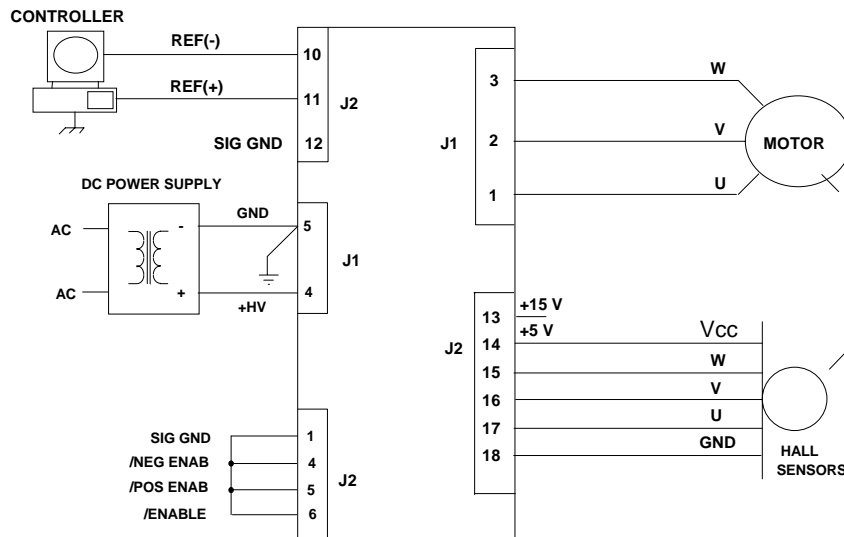

APPLICATION INFORMATION

To use the model 503 set up the internal header with the components that configure the transconductance, current limits, and load inductance. Current-limits and load inductance set up the amplifier for your particular motor, and the transconductance defines the amplifiers overall response in amps/volt that is required by your system.

COMPONENT HEADER SETTINGS

Use the tables provided to select values for your load and system. We recommend that you use these values as starting points, adjusting them later based on tests of the amplifier in your application.

LOAD INDUCTANCE (RH1,CH2)

Maximizes the bandwidth with your motor and supply voltage. First replace CH2 with a jumper (short). Adjust the value of RH1 using a step of 1A or less so as not to experience large signal slew-rate limiting. Select RH1 for the best transient response (lowest risetime with minimal overshoot). Once RH1 has been set. choose the smallest value of CH2 that does not cause additional overshoot or degradation of the step response.

TRANSCONDUCTANCE (RH6,7)

The transconductance of the 503 is the ratio of output current to input voltage. It is equal to $10k\Omega/RH6$ (Amps/Volt). RH6,and RH7 should be the same value and should be 1% tolerance metal film type for good common-mode noise rejection.

CURRENT LIMITS (RH3, 4, & 5)

The amplifier operates at the 5A continuous, 10A peak limits as delivered. To reduce the limit settings, choose values from the tables as starting points, and test with your motor to determine final values. Limit action can be seen on current monitor when output current no longer changes in response to input signals. Separate control over peak, continuous, and peak time limits provides protection for motors, while permitting higher currents for acceleration.

SETUP BASICS

1. Set RH1 and CH2 for motor load inductance (see following section).
2. Set RH3, 4, & 5 if current limits below standard values is required.
3. Ground the /Enable (/Enable Pol open), /Pos Enable, and /Neg Enable inputs to signal ground.
4. Connect the motor Hall sensors to J2 based on the manufacturers suggested signal names. Note that different manufacturers may use A-B-C, R-S-T, or U-V-W to name their Halls. Use the required Hall supply voltage (+5 or +15V). *Note that there is a 30 mA limit at +5V. Encoders that put-out Hall signals typically consume 200-300 mA, so if these are used, then they must be powered from an external power supply.*
5. Connect J1-4,5 to a transformer-isolated source of DC power, +18-55V. Ground the amplifier and power supply with an additional wire from J1-5 to a central ground point.

6. With the motor windings disconnected, apply power and slowly rotate the motor shaft. Observe the Normal (green) led. If the lamp blinks while turning then the 60/120° setting is incorrect. If J2-2 is open, then ground it and repeat the test. In order to insure proper operation, the correct Hall phasing of 60° or 120° must be made.
6. Turn off the amplifier and connect the motor leads to J1-1,2,3 in U-V-W order. Power up the unit. Apply a sinusoidal reference signal of about 1 Hz. and 1Vrms between Ref(+) and Ref(-), J2-10,11.

7. Observe the operation of the motor as the current monitor signal passes through zero. When phasing is correct the speed will be smooth at zero crossing and at low speeds. If it is not, then power-down and re-connect the motor.

There are six possible ways to connect the motor windings, and only one of these will result in proper motor operation. The six combinations are listed in the table below. Incorrect phasing will result in erratic operation, and the motor may not rotate. When the correct combination is found, record your settings.

	J1-1	J1-2	J1-3
#1	U	V	W
#2	V	W	U
#3	W	U	V
#4	U	W	V
#5	W	V	U
#6	V	U	W

GROUNDING & POWER SUPPLIES

Power ground and signal ground are common (internally connected) in this amplifier. These grounds are isolated from the amplifier case which can then be grounded for best shielding while not affecting the power circuits.

Currents flowing in the power supply connections will create noise that can appear on the amplifier grounds.

This noise will be rejected by the differential amplifier at the reference input, but will appear at the digital inputs. While these are filtered, the lowest noise system will result when the power-supply capacitor is left floating, and each amplifier is grounded at its power ground terminal (J1-5). In multiple amplifier configurations, always use separate cables to each amplifier, twisting these together for lowest noise emission. Twisting motor leads will also reduce radiated noise from pwm outputs. If amplifiers are more than 1m. from power supply capacitor, use a small (500-1000 μ F.) capacitor across power inputs for local bypassing.

APPLICATION INFORMATION (CONT'D)

COMPONENT HEADER

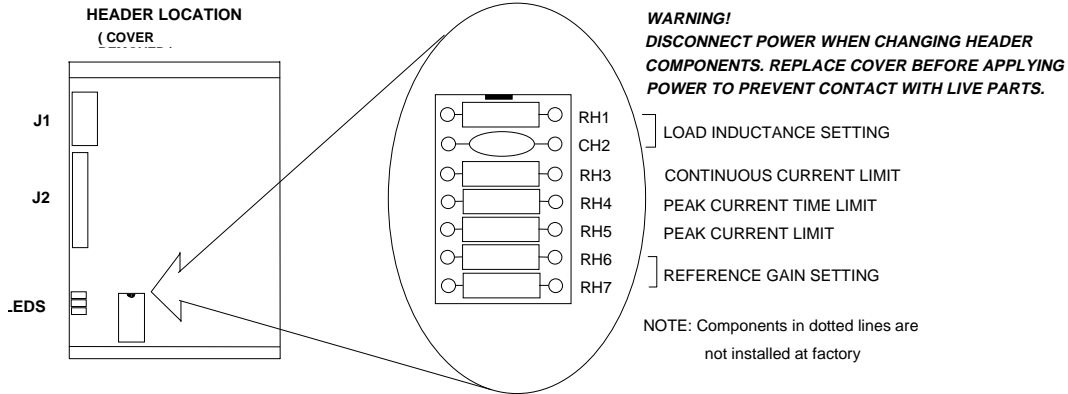

CONTINUOUS CURRENT LIMIT (RH3)

I_{cont} (A)	$RH3$ (Ω)
5	<i>open</i> *
4	20k
3	8.2k
2	3.9k
1	1.5k

INPUT TO OUTPUT GAIN SETTING (RH6, RH7)

Note 1

Example: Standard value of RH6 is 10k Ω , thus $G = 1$ A/V

PEAK CURRENT LIMIT (RH5) Note 3

I_{peak} (A)	$RH5$ (Ω)
10	<i>open</i> *
8	12k
6	4.7k
4	2k
2	750

LOAD INDUCTANCE SETTING (RH1 & CH2) Note 2

Load (mH)	RH1	CH2
0.2	49.9 k	1.5 nF
1	150 k	1.5 nF
3	<i>499 k</i>	<i>1.5 nF</i> *
10	499 k	3.3 nF
33	499 k	6.8 nF
40	499 k	10 nF

PEAK CURRENT TIME-LIMIT (RH4) Note 4

T_{peak} (s)	$RH4$ (Ω)
0.5	<i>open</i> *
0.4	10 M
0.2	3.3 M
0.1	1 M

Times shown are for 10A step from 0A

Notes: * **Standard values installed at factory are shown in italics.**

- RH6 & RH7 should be 1% resistors of same value.
- Bandwidth and values of RH1, CH2 are affected by supply voltage and load inductance. Final selection should be based on customer tests using actual motor at nominal supply voltage.
- Peak current setting should always be greater than continuous current setting.
- Peak times will double when current changes polarity. Peak times decrease as continuous current increases.

TECHNICAL SPECIFICATIONS

Typical specifications @ 25°C ambient, +HV = +55VDC. Load = 200µH. in series with 1 ohm unless otherwise specified.

OUTPUT POWER

Peak power	±10A @ 50V for 0.5 second, 500W
Unidirectional	
After direction change	±10A @ 50V for 1 second, 500W
Continuous power	±5A @ 50V, 250W

OUTPUT VOLTAGE

Vout = 0.97HV -(0.4)(Iout)

MAXIMUM CONTINUOUS OUTPUT CURRENT

Convection cooled, no conductive cooling	±2A @ 35°C ambient
Mounted on narrow edge, on steel plate, fan-cooled 400 ft/min	±5A @ 55°C

LOAD INDUCTANCE

Selectable with components on header socket	200 µH to 40mH (Nominal, for higher inductances consult factory)
---------------------------------------------	------------------------------------------------------------------

BANDWIDTH

Small signal	-3dB @ 2.5kHz with 200µH load
Note: actual bandwidth will depend on supply voltage, load inductance, and header component selection	

PWM SWITCHING FREQUENCY

25kHz

ANALOG INPUT CHARACTERISTICS

Reference	Differential, 20K between inputs with standard header values
-----------	--------------------------------------------------------------

GAINS

Input differential amplifier	X1 as delivered. Adjustable via header components RH6, RH7
PWM transconductance stage	1 A/V (output vs. input to current limit stage)

OFFSET

Output offset current (0 V at inputs)	20 mA max. (0.2% of full-scale)
Input offset voltage	20 mV max (for 0 output current, RH6,7 = 10kΩ)

LOGIC INPUTS

Logic threshold voltage	HI: ≥ 2.5V , LO: ≤1.0V, +5V Max on all logic inputs
/Enable	LO enables amplifier (/Enable Pol open) , HI inhibits; 50 ms turn-on delay
/POS enable, /NEG enable	LO enables positive and negative output currents, HI inhibits
/Reset	LO resets latching fault condition, ground for self-reset every 50 ms.
/Enable Pol (Enable Polarity)	LO reverses logic of /Enable input only (HI enables unit, LO inhibits)

LOGIC OUTPUTS

+Normal	HI when unit operating normally, LO if overtemp, output short, disabled, or power supply (+HV) out of tolerance HI output voltage = 2.4V min at -3.2 mA max., LO output voltage = 0.5V max at 2 mA max. Note: Do not connect +Normal output to devices that operate > +5V
---------	-------------------------------------------------------------------------------------------------------------------------------------------------------------------------------------------------------------------------------------------------------------------------------------------

INDICATORS (LED's)

Normal (green)	ON = Amplifier enabled, no shorts or overtemp, power within limits
Power fault (red)	ON = Power fault: +HV <18V OR +HV > 55V
Short/Overtemp (red)	ON = Output short-circuit or over-temperature condition

CURRENT MONITOR OUTPUT

±5V @ ±10A (2A/volt), 10kΩ, 3.3nF R-C filter

DC POWER OUTPUTS

+5VDC	30mA (Includes power for Hall sensors)
+15VDC	10mA
Total power from all outputs not to exceed 200mW.	

PROTECTION

Output short circuit (output to output, output to ground)	Latches unit OFF (self-reset if /RESET input grounded)
Overtemperature	Shutdown at 70°C on heatplate (Latches unit OFF)
Power supply voltage too low (Undervoltage)	Shutdown at +HV < 18VDC (operation resumes when power >18VDC)
Power supply voltage too high (Overvoltage)	Shutdown at +HV > 55VDC (operation resumes when power <55VDC)

POWER REQUIREMENTS

DC power (+HV)	+18-55 VDC @ 10A peak.
Minimum power consumption	2.5 W
Power dissipation at 5A output, 55VDC supply	10W
Power dissipation at 10A output, 55VDC supply	40W

THERMAL REQUIREMENTS

Storage temperature range	-30 to +85°C
Operating temperature range	0 to 70°C baseplate temperature

MECHANICAL

Size	3.27 x 4.75 x 1.28 in. (83 x 121 x 33mm)
Weight	0.52 lb (0.24 kg.)

CONNECTORS

Power & motor	Weidmuller: BL-125946; Phoenix: MSTB 2.5/5-ST-5.08
Signal & Halls	Molex: 22-01-3167 housing with 08-50-0114 pins

Model 503
DC Brushless Servo Amplifier

OUTLINE DIMENSIONS

Dimensions in inches (mm.)

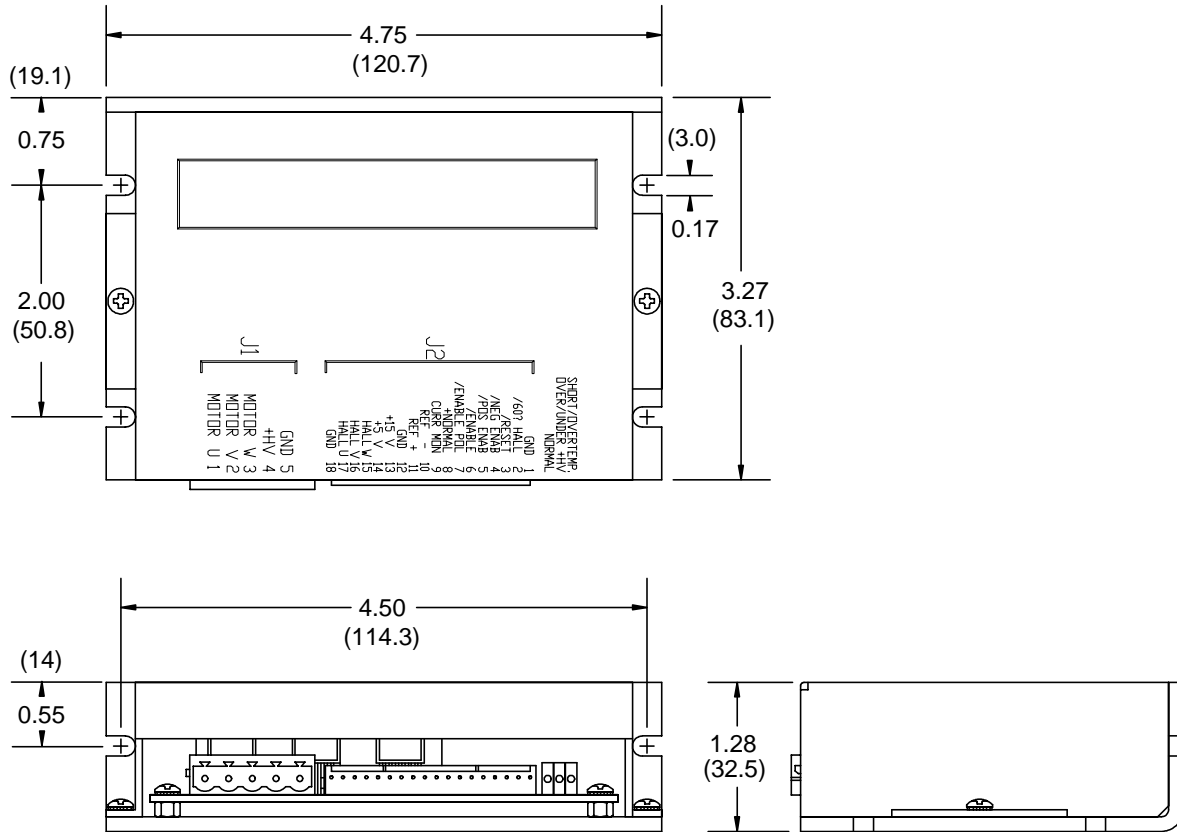

ORDERING GUIDE

Model 503	5A Continuous, 10A Peak, +18-55VDC Brushless Servoamplifier
-----------	-------------------------------------------------------------

OTHER BRUSHLESS AMPLIFIERS

- Model 505** Same power output as 503. Adds Hall / Encoder tachometer feature for velocity loop operation.
- 5001 Series** Six models covering +24-225VDC operation, 5-15A continuous, 10-30A peak. With optional Hall / Encoder tachometer, and brushless tachometer features.
- Model 513R** Resolver interface for trapezoidal-drivemotors. Outputs A/B quadrature encoder signals and analog tachometer signal for velocity loop operation. +24-180VDC operation, 13A continuous, 26A peak.