

**LINE-POWERED DC BRUSHLESS SERVO AMPLIFIERS**

**FEATURES**

- Operates directly from AC mains with full optical isolation between signal and power stages.
- Drives DC brushless motors with 60° or 120° Halls in six-step (trapezoidal) mode
- Independent settings for peak and continuous current, and peak-time.
- External or hardwired control of peak and continuous current limits.
- *DriveTorque* mode switches from velocity to torque mode for fastener-driving, bottle capping, etc.
- Separate motor and signal Sub-D type connectors for simpler cabling
- +5V @ 200mA powers motors with “commutating encoders”
- FAIL-SAFE ENABLE INPUT  
 Ground or +5V level select  
 Pull-up or pull-down select
- Dual Status outputs (amp NORMAL and amp READY)
- FAULT PROTECTIONS  
 Short-circuits  
     output to output  
     output to gnd  
 Over / under voltage  
 Over temperature  
 Self-reset or latch-off
- 3kHz bandwidth  
 Wide load inductance range  
 0.4~40 mH.

**THE OEM ADVANTAGE**

- Production amplifiers can be pre-configured at the factory for volume production
- Built in power supply!

MODEL	POWER	I-CONT (A)	I-PEAK (A)
5224AC	32~132VAC	10	20
5424AC	32~264VAC	10	20



The 5xx4AC models are PWM servoamplifiers for Hall commutated DC brushless motors operating in six-step (trapezoidal) mode. Models operate from 115 or 230VAC single-phase AC mains. Signal, logic, Halls, encoder, and monitor signals are all optically isolated from the mains.

Built with surface-mount technology, these amplifiers offer a full complement of features for DC brushless motor control. Torque-mode operation is standard, and there are two modes of velocity-loop operation. Frequency to voltage conversion of Hall or encoder signals gives tachless velocity-loop operation. Output voltage control gives velocity loop operation without the use of encoder or Hall signals.

Torque mode is used typically with digital controllers that calculate position and velocity from the motors encoder. Hall tach operation works well for high speed applications such as spindles. Encoder tach velocity loops give a wide speed range and lower ripple near zero velocity. Voltage mode is smooth around zero, and has enough speed regulation to work well with PLC's, or motion control IC's.

An internal solderless sockets permits users to configure the various gain and current limit settings to customize the amplifiers for a wide range of loads and applications. Header components permit compensation over a wide range of load inductances to maximize bandwidth with different motors.

Separate current-limits provide protection for motors while optimizing acceleration characteristics. Peak current, continuous current, and peak-time are individually settable via the internal header, or by external signals.

DriveTorque mode for fastener driving applications permits external switching between velocity and torque mode. Screws are driven in at constant speed using voltage-mode feedback until the external controller senses increased current. Then, mode is switched to torque mode to set screw at programmed torque.

The /Enable input active logic-level is switch-selectable to ground or +5V to interface with all types of control cards. Fail-safe operation in either polarity results from an internal jumper that selects the default input level and input resistor pull-up or pull-down connections so that the amplifier shuts down with no input.

MOSFET (5224AC) and IGBT (5424AC) output stages deliver four-quadrant power for bi-directional acceleration and deceleration of motors. For high-inertia loads, an external regenerative energy dissipater is available.

All models are protected against output short circuits (output to output and output to ground) and heatplate overtemperature. With the /Reset input open the amplifier will latch off until powered-down or the /Reset input is toggled. The amplifier will reset itself automatically from faults if the /Reset input is wired to GND.

# MODELS 5224AC, 5424AC

## LINE-POWERED DC BRUSHLESS SERVO AMPLIFIER

### TECHNICAL SPECIFICATIONS

MODEL	5224AC	5424AC
<b>OUTPUT POWER</b>		
Peak power	20A @ 110V	20A @ 205V
Peak time	1 sec at peak power or 2 secs. after polarity reversal	
Continuous power	10A @ 130V	10A @ 250V
<b>OUTPUT VOLTAGE</b>		
On-resistance (Ro, ohms)	0.2	0.15
Max PWM Peak Output Voltage	$\pm V_{out} = (VAC \times 1.41 \cdot -2) \times (0.97) - (R_o) \times (I_o)$	
Maximum effective output voltage at continuous power	130V @ 10A	250V @ 10A
Maximum effective output voltage at peak power	110V @ 20A	205V @ 20A
<b>INPUT POWER</b>		
Mains voltage	32~132VAC, 47~63Hz	32~264VAC, 47~63Hz
Mains current @ continuous output rating	16A	16A
Inrush current on startup	37 A max	37 A max
External mains fuse rating	20A/125V	20A/250V
<b>LOAD INDUCTANCE</b>		
Minimum inductance	400 $\mu$ H.	400 $\mu$ H.
Maximum inductance	No maximum. See chart of load inductance values. Bandwidth varies with inductance and header parts.	
<b>BANDWIDTH</b>	Small signal	-3dB @ 3kHz with minimum load at nominal supply voltage. Varies with load inductance and header values
<b>PWM OUTPUTS</b>		
PWM frequency	25kHz	
Modulation	Center-weighted, 50% duty cycle at 0V output	
<b>REFERENCE INPUT</b>		
Differential, 94K $\Omega$ between inputs, $\pm$ 20V maximum		
<b>POTENTIOMETERS (15 turn)</b>		
Ref Gain	Default = CW	CCW attenuates Reference input from x1 to 0
Tach Gain	Default = CCW	CW increases speed ( decreases feedback from tachometer ). Note: fully CW = 5% of max
Loop Gain	Default = CCW	CW increases loop gain in velocity mode, current gain in torque mode
Integ Freq	Default = CCW	Integrator zero-gain frequency in velocity mode. CW increases stiffness
Balance/Test	Default = center	Use to set output current or rpm to zero; or use as $\pm$ 10V test input if RH9 set to 50k $\Omega$
<b>DIP SWITCHES</b>		
S1:	Velocity loop integrator control. ON: Torque mode, integrator disabled. OFF: Velocity mode, integrator enabled.	
S2, S3:	Feedback mode control. See Applications section for details.	
S4:	/Enable input active polarity. OFF (default): Gnd enables amplifier, open or +5V inhibits. ON: Gnd inhibits, open enables	
<b>LOGIC INPUTS</b>		
/Enable	Default = GND	GND enables amplifier, open or >2.5V inhibits with S1 OFF. If S4 ON then GND inhibits See following section on Fail-Safe operation for JP4 settings.
/POS enable, /NEG enable	Default = GND	Response time: 1 ms. From enable active to amplifier output ON GND enables, open or >2.5V inhibits positive/negative output currents ( S4 has no effect )
/Reset	Default = Open	GND resets latching fault condition, ground for self-reset every 50 ms.
/Motemp	Default = GND	Motor temperature sensor. Typically normally closed bimetal sensor. Open = overtemp
/Force	Default = Open	Velocity to torque mode switching control. Ground disconnects velocity loop components (Ref Gain, Tach Gain, Loop Gain, Integ Freq, and Balance pots, and all related header parts). Mode changes to torque, RH10 controls transconductance. See application section for details.
Input resistance	10k $\Omega$ (Jumper J1-A selects connection to +5V or ground <sup>1</sup> ), R-C filters on inputs	
Logic threshold voltage	2.5V (Schmitt trigger inputs with hysteresis, 74HC14)	
Input voltage range	0V to +32VDC	
<b>FAIL-SAFE ENABLE INPUT</b>		
Internal jumper JP4 selects +5V or GND connection for input pull-up resistors to /Enable input only so that amplifier will default to <i>disabled</i> condition if inputs are open-circuit, or wires are broken. (See Applications section for details)		
<b>LOGIC OUTPUTS</b>		
/Normal	LO (current sinking) when Normal LED is ON; HI when LED is OFF	
HI output voltage	+5V (no load). Output is N-channel mosfet drain terminal with 10k $\Omega$ pullup resistor to +5V	
LO output voltage	On resistance Ro = 5 $\Omega$ . Max sink current of 250mA. max off-voltage = 50VDC	
Amp OK	N-channel opto-isolator is ON when amp is OK: Buss volts OK AND NOT (output short OR overtemp) AND NOT Motemp switch open.	
ON current	4 mA.	
Max voltage	32 VDC	
<b>STATUS LED</b>		
Bicolor LED changes color and flashes to indicate amplifier operating status		
Green = Normal	Amplifier enabled AND Amp OK (see above)	
blinking green = Ready	Amplifier OK, will run when enabled	
Red = Buss Fault, non-latching	Over or under-voltage condition. Amplifier recovers when voltage is in normal range. OR Motemp switch open.	
Red/blinking = Latching Fault	Output overcurrent (short circuit) or overtemp condition. Ground /Reset or power amp off/on to clear condition	
<b>MONITOR OUTPUTS</b>		
Current Ref	Current demand signal to PWM stage: $\pm$ 10V = $\pm$ Ipeak	
Current Monitor	Motor winding current: $\pm$ 10V @ $\pm$ Ipeak (1k $\Omega$ , 33nF R-C filter)	
Feedback	Monitor signal for Hall/encoder tachometer, voltage feedback. $\pm$ 5V = 100% of feedback signal normal range	
<b>DC POWER OUTPUTS</b>		
+5V @ 250 mA max (J2-11, J3-23). Power for Halls and/or encoder.		
+10VDC @ 5 mA (J3-24) -10VDC @ 5mA (J3-25)		
Note: maximum power from all dc outputs not to exceed 1.4W		

# MODELS 5224AC, 5424AC LINE-POWERED DC BRUSHLESS SERVO AMPLIFIER

## PROTECTIVE FEATURES

Short circuit (output to output, output to ground) OverTemperature  Undervoltage Overvoltage  Current-limiting (foldback)	Latches unit OFF (Power off/on, or ground at /Reset input resets) Latches unit OFF at 70°C on heatplate ( Power off/on, or ground at /Reset input resets) <i>Wire /Reset input to ground for automatic reset after latching fault</i> Shutdown at DC buss < 45VDC Shutdown at DC buss > 195VDC (524AC), or DC buss > 390VDC (5424AC) ( Amplifier operation resumes when power is NOT undervoltage or NOT overvoltage ) Output current set by header components (peak, continuous, & peak-time)
---	--

## THERMAL REQUIREMENTS

Storage temperature range -30°C to +85°C  
 Operating temperature range 0° to 70°C baseplate temperature  
 Thermal resistance (heatplate to ambient):  
 No heatsink or fan: 0.92 deg C/W, no heatsink with fan: 0.51 deg C/W  
 With heatsink: no fan: 0.6 deg C/W; with heatsink and fan: 0.23 deg C/W.

## MECHANICAL

Size  Weight	7.50 x 7.0 x 2.72 in. (190 x 178 x 69 mm) without optional heatsink 7.5 x 7.0 x 4.72 in. (190 x 178 x 120mm) with optional heatsink 3.71 lbs (1.69 kg) without optional heatsink. Add 3.2 lb ( 1.47 kg ) for heatsink.
--------------------	--

## CONNECTORS

J1: Power & motor J2: Halls / Options J3: Signal	9-position terminal strip 15-position female Sub-D type. #4-40 standoffs for cable shell lock screws 25-position female Sub-D type. #4-40 standoffs for cable shell lock screws Connector shells are connected to amplifier chassis for grounding/shielding
--	--

## PANEL LAYOUT

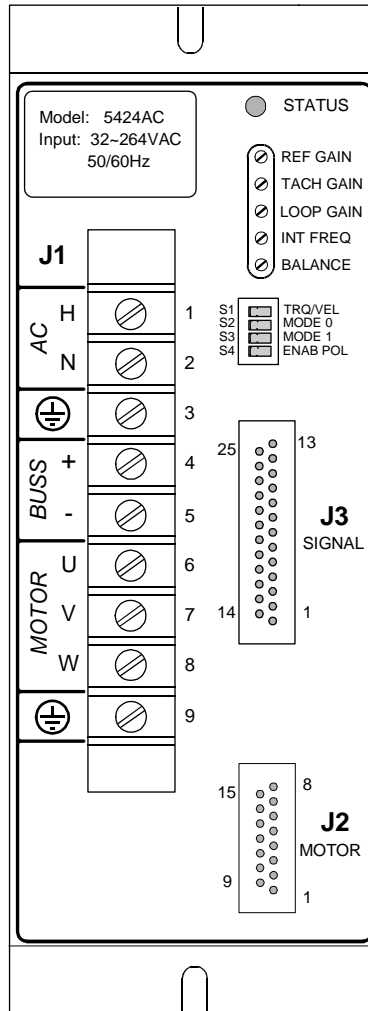

# MODELS 5224AC, 5424AC

## LINE-POWERED DC BRUSHLESS SERVO AMPLIFIER

### AMPLIFIER CONNECTIONS

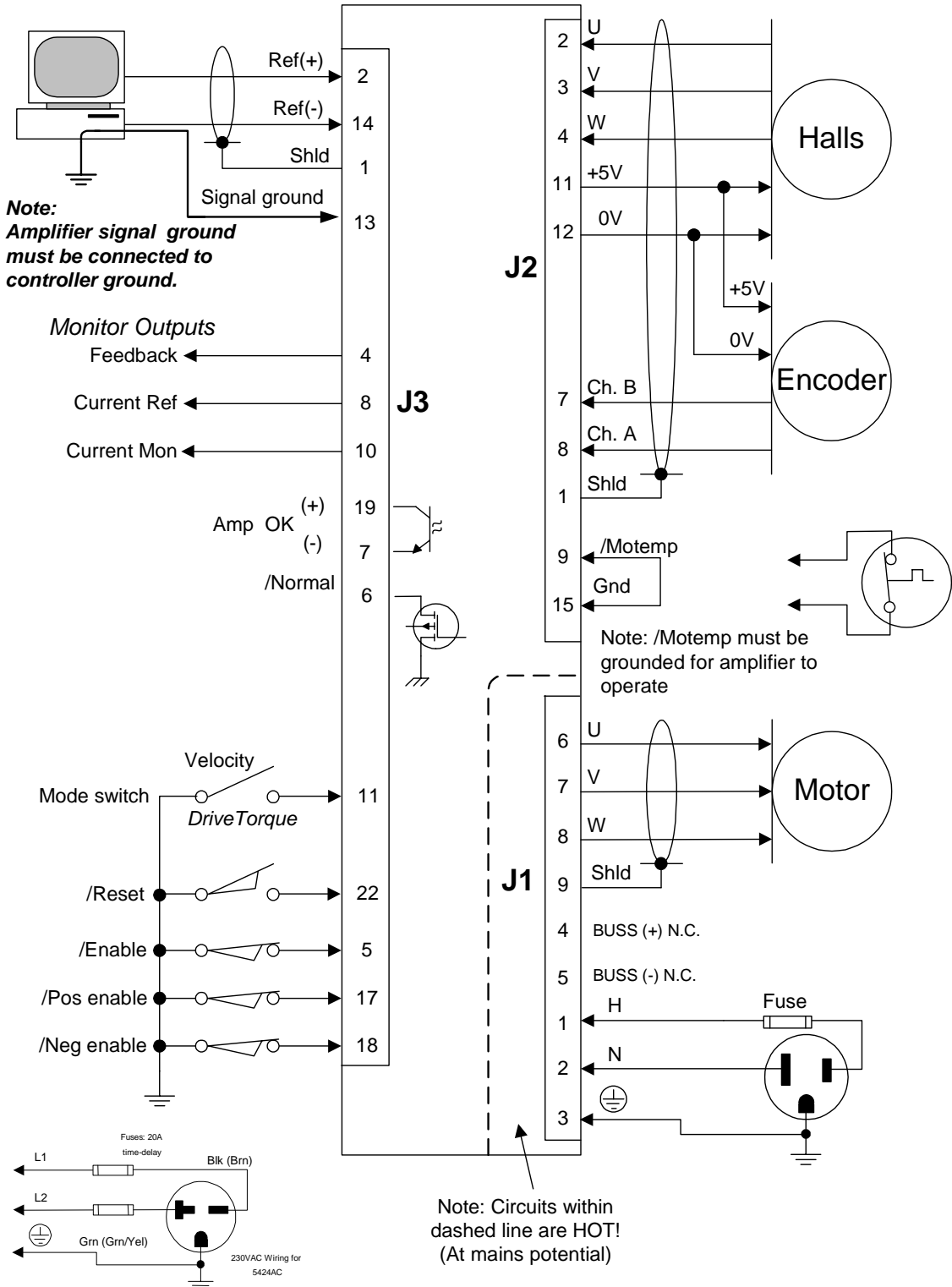

# MODELS 5224AC, 5424AC

## LINE-POWERED DC BRUSHLESS SERVO AMPLIFIER

### J1 Power and motor winding connections

Connector type: Barrier-block. Screw-terminal connections. #6-32 locking screws with cable clamps.

PIN	SIGNAL	FUNCTION
1	H	AC Power Input Hot (black or brown wire from AC mains)
2	N	AC Power Input Neutral (white or blue wire from AC mains)
3	GND	Chassis safety ground (green or green/yellow wire from AC mains)
4	Buss (+)	Positive terminal of internal DC power supply (N.C.)
5	Buss (-)	Negative terminal of internal DC power supply (N.C.)
6	Motor U	Amplifier output to "U" winding of motor
7	Motor V	Amplifier output to "V" winding of motor
8	Motor W	Amplifier output to "W" winding of motor
9	GND	Chassis safety ground. Also for cable shield of motor cable.

### J2 Motor Hall and encoder connections

Connector type: Female Sub-D, 15-position, #4-40 standoffs for cable shell

PIN	SIGNAL	FUNCTION
1	Safety GND	Chassis ground. Use to ground cable shield. Not connected to internal signal ground.
2	Hall U	Digital Hall inputs for "U"
3	Hall V	Digital Hall inputs for "V"
4	Hall W	Digital Hall inputs for "W"
5	Analog Tach	Brush tachometer input
6	N.C.	
7	Encoder B channel	
8	Encoder A channel	
9	Motemp	<i>Note: Must be grounded for amplifier to operate (Connect to J2-12, 14 or 15)</i>
10	N.C.	
11	+5V @ 200 mA.	DC power for encoders and Halls (Note 1)
12	0V.	Signal ground for +5V and Halls.
13	N.C.	
14	0V.	Signal ground for +5V and Halls.
15	0V.	Signal ground for +5V and Halls.

### J3 Signal connections

Connector type: Female Sub-D, 25-position, #4-40 standoffs for cable shells

PIN	SIGNAL	FUNCTION	PIN	SIGNAL	FUNCTION
1	Safety GND	Chassis ground. Use to ground cable shield. Not connected to internal signal ground (J3-12,13,15,16).			
2	Ref (+)	Positive terminal of differential +/-10V analog command input	14	Ref (-)	Negative terminal of differential +/-10V analog command input
3	Analog Tach	Brush tachometer input	15	0V.	Signal ground.
4	Feedback	Hall, encoder, or Vout FB	16	0V.	Signal ground.
5	/Enable input	Amplifier enable	17	/Pos Enable input	
6	/Normal output	Mosfet output amp status	18	/Neg Enable input	
7	Amp OK (-) output	Opto-isolator emitter (NPN)	19	Amp OK (+) output	Opto-isolator collector (NPN)
8	Current Ref output		20	Ext Ipeak	External setting of peak curr
9	Aux input		21	Ext Icont	External setting of cont curr
10	Current Monitor Out		22	/Reset input	
11	/DrivTorq	Ground enables Drive-Torque mode.	23	+5V @ 200 mA.	Auxiliary DC power for user devices (Note 1)
12	0V.	Signal ground.	24	+10V @ 5 mA	Auxiliary DC power
13	0V.	Signal ground.	25	-10V @ 5 mA	Auxiliary DC power

Notes: 1. +5V @ 200mA connects to both J3-23 and J2-11. Combined current from both pins must not exceed 200mA.

# MODELS 5224AC, 5424AC LINE-POWERED DC BRUSHLESS SERVO AMPLIFIER

## FUNCTIONAL DIAGRAM

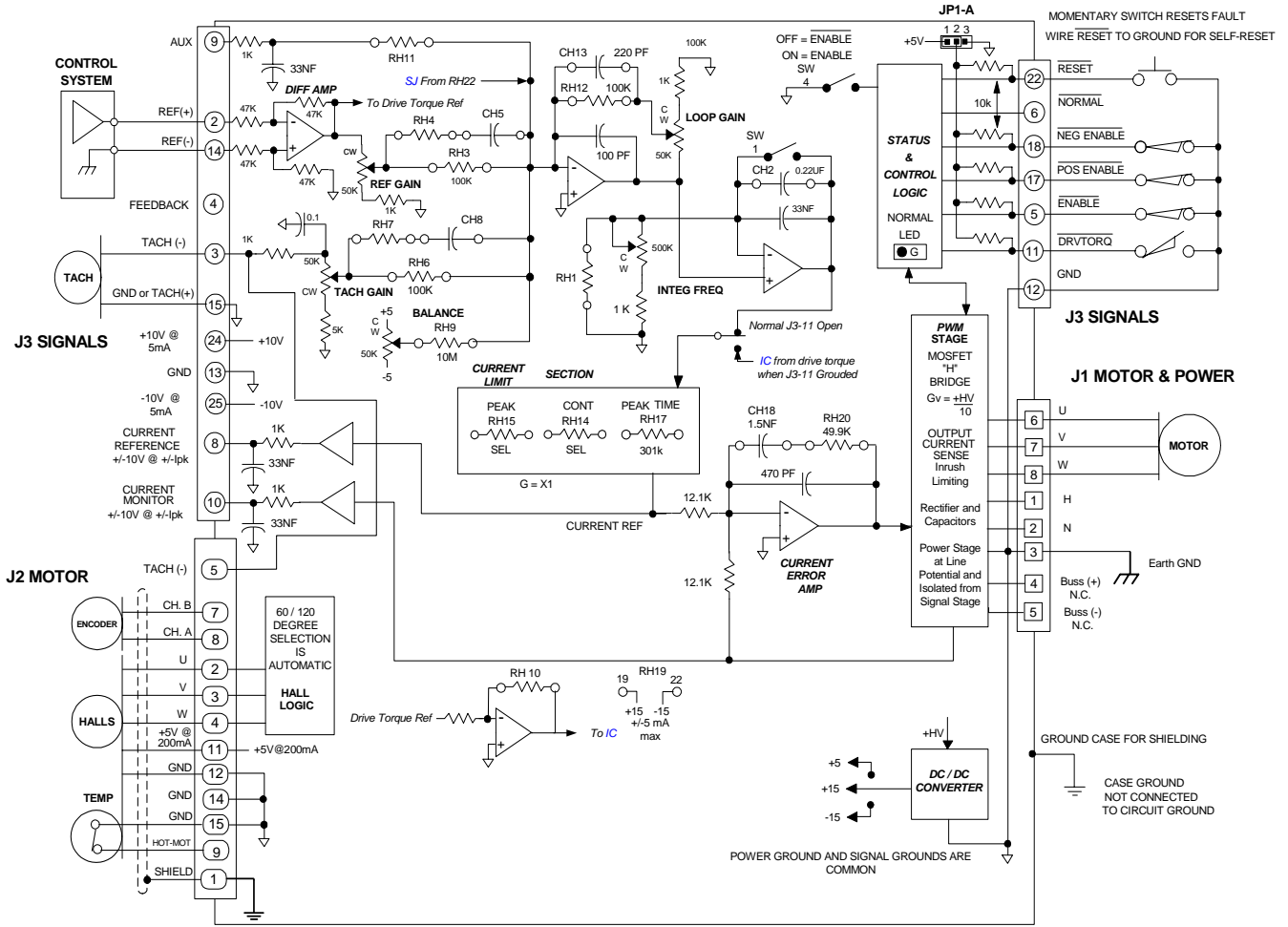

## FEEDBACK MODES FUNCTIONAL DIAGRAM

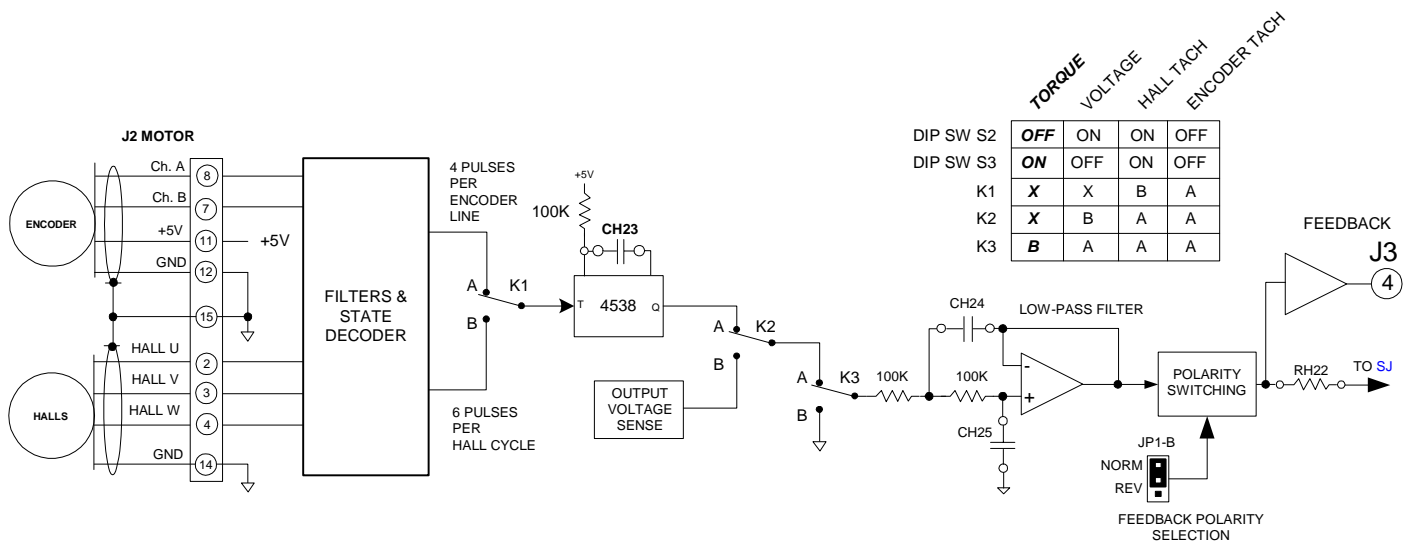

# MODELS 5224AC, 5424AC

## LINE-POWERED DC BRUSHLESS SERVO AMPLIFIER

### DIP SWITCH FUNCTIONS

The default configuration for the amplifier is *torque mode* (no feedback). To enable the velocity feedback modes described below, set the DIP switches according to the chart below.

Note: Default positions shown in ***bold & italics*** (ON is toward PC board, OFF is away from PC board)

SW	NAME	SEL	DESCRIPTION
S1	INTEG	<b><i>ON</i></b>	<b><i>Torque Mode (velocity integrator OFF)</i></b>
		OFF	Velocity feedback mode (integrator ON)
S2	MODE 0	<b><i>OFF</i></b>	Amplifier operating mode selection ( <b><i>Default = torque mode</i></b> )
S3	MODE 1	<b><i>ON</i></b>	
S4	EN POL	ON	/Enable input disables amplifier if ground. Open or >2.5V enables.
		<b><i>OFF</i></b>	<b><i>/Enable input ground-active. Open or &gt;2.5V disables amplifier.</i></b>

Note: "X" in table below means that switch setting doesn't matter.

S2	S3	J3-11	FUNCTION	DESCRIPTION
<b><i>OFF</i></b>	<b><i>ON</i></b>	<b><i>HI</i></b>	<b><i>Torque-Mode</i></b>	<b><i>No internal feedback</i></b>
ON	OFF	HI	Output voltage feedback	Output voltage control
ON	ON	HI	Hall speed control mode	Frequency to voltage conversion of Halls
OFF	OFF	HI	Encoder speed control mode	Frequency to voltage conversion of encoder
X	X	LO	<b><i>DriveTorque</i></b> mode	RH10 sets current-gain. All pots out of circuit.

### POTENTIOMETER FUNCTIONS

POT	DEFAULT	DESCRIPTION
REF GAIN	CW	Input reference signal attenuation. Controls overall amplifier gain (amps/volt or rpm/volt) without affecting response. Full CCW attenuates reference signal to zero.
TACH GAIN	CCW	Tachometer feedback control. CCW = maximum feedback (lowest speed, fastest response), CW = minimum feedback (highest speed, slowest response). Range = 20:1 (maximum to minimum speed).
LOOP GAIN	CCW	Response control for velocity loop: CW increases bandwidth, CCW decreases. In torque mode: CW increases amps/volt.
INTEG FREQ	CCW	DIP switch S1 must be OFF for this pot to function. In velocity mode, CW increases stiffness, makes loop less stable, CCW decreases stiffness, makes loop more stable. <b><i>Too much CW leads to violent oscillation.</i></b>
BALANCE	Center	Sets velocity to zero, or output current to zero with zero input.

### LED INDICATOR FUNCTIONS

Color and state of LED indicates amplifier operating conditions:

LED COLOR	CONDITION (Note 2)	ACTION REQUIRED TO ENABLE
Flashing Green	Ready	Ground /Enable input (J3-5) (Note 2)
Green	Normal	None. Normal "RUN" condition.
Red	Power Fault	Bring AC voltage into range.
Flashing Red	Latching Fault	Ground /Reset input, or cycle AC power OFF/ON

Notes:

- Fault = output short circuit or heatplate overtemperature. Amplifier 'latches' off and stays off until reset.  
 Amp OK = Internal buss voltage is within limits AND NOT-Fault  
 Ready = Amp OK AND NOT-enabled  
 Normal = Amp OK AND enabled
- With S4 OFF and jumper J1-AA on pins 1-2 (default), grounding /Enable will enable amplifier.  
 If S4 is ON, grounding J3-5 *inhibits* the amplifier: voltage must be >2.5V to enable amplifier.  
 If J1-AA is on pins 1-2 (default), amplifier will be enabled whenever J3-5 is open or >2.5V.  
 With J1-AA on pins 2-3, the enable input is pulled to ground via a 10k resistor, disabling the amplifier when J3-5 is open (Fail-Safe operation). To enable the amplifier, the controller must *pull-up* the 10k resistor to >2.5V to enable amplifier

# MODELS 5224AC, 5424AC LINE-POWERED DC BRUSHLESS SERVO AMPLIFIER

## FAIL-SAFE JUMPER FUNCTION

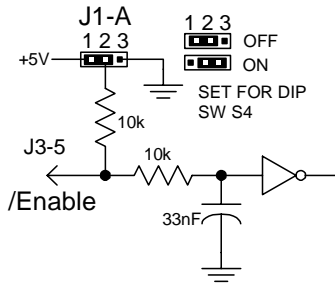

Internal jumper J1-A sets the open-pin voltage for the /Enable input (J3-5). For FAIL-SAFE operation, the amplifier should shut down if J3 is disconnected, or if the wire to the /Enable input is broken. For this to work, J1-A should be set according to the position of DIP switch S4 as follows:

S4 OFF (default): /Enable input is ground active. J1-A set to pins 1-2 so that input pulls up to +5V, disabling amplifier.  
S4 ON: /Enable input functions as +Enable, /Disable. Set J1-A to pins 2-3 so that input voltage is pulled-down to ground if input is open.

## AMP-NORMAL OUTPUT

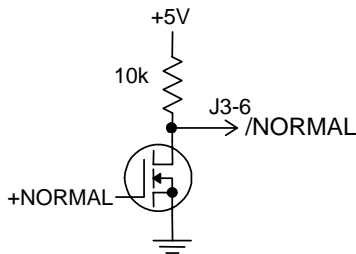

N-channel mosfet with 10k ohm resistor connected to +5V. Maximum voltage: 50VDC. Maximum current 250mA. On-resistance = 5 ohms.

Output is LO (mosfet ON) whenever amplifier is enabled and NORMAL (LED green).  
Output is HI (mosfet OFF) whenever amplifier is NOT-enabled, or FAULT occurs.

## OPTOISOLATED AMP OK OUTPUT

The Amp OK signal indicates amplifier ready to run status. It is completely optically isolated from the amplifier. The input of the optocoupler is driven by the amplifier logic circuits, and the output is a floating NPN transistor with both terminals brought to signal connector

J3 as shown below.

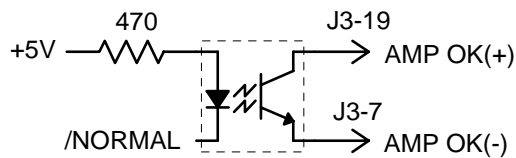

Maximum voltage = 32VDC. ON current = 4mA. minimum Output transistor ON voltage: 0.4 at 4mA

## DRIVETORQUE MODE

This mode is most useful in fastener-drive applications where the amplifier is operated in a velocity mode to drive the fastener in at a constant speed until the controller senses that the current has reached a set value. Then the controller grounds the /DRVTRQ input switching the amplifier into torque mode that applies a set current to the fastener to drive it into position at a constant torque value. With J3-11 open (default) amplifier operates in velocity mode. This can be switch-selected to be Hall, encoder, output voltage, or analog tachometer controlled.

When J3-11 is grounded, DriveTorque mode is enabled, and amplifier switches to torque mode with transconductance controlled by RH10. The REF GAIN, LOOP GAIN, INTEG FREQ, and BALANCE pots have no effect in this mode. The current gain is controlled by this simple equation:

$$\text{Gain} = \frac{\text{RH10 (kOhms)}}{10} \quad (\text{A/V})$$

## PEAK CURRENT LIMIT SET

Control of the peak current limits can be made externally via connector pin J3-20. A resistor can be connected between this pin and signal ground (J3-12, 13, 15, or 16), or the pin can be driven by a voltage between 0 and +10VDC. Using this technique, the current limit can be controlled over a range of 100% to 10% of the amplifiers peak rated current. The figure below shows the circuit. RH15 internal.

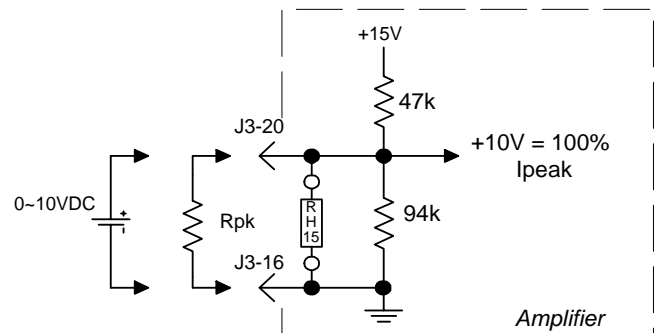

The table below give values of the external control voltage, or external control resistor for various values of peak current:

I <sub>peak</sub>	R <sub>ext</sub>	V <sub>ext</sub>
20	<out>	10
18	180k	8.8
16	91k	7.7
14	56k	6.6
12	39k	5.6
10	24k	4.6
8	15k	3.5
6	10k	2.5
4	5k	1.4
2	1.2k	0.4

These values are within 10%, typically. For greater accuracy, measure Current Ref and select parts for exact limit value.

## ENCODER TACH OPERATION

### Hall tach vs. encoder tach

Digital Hall or encoder signals are converted into an analog tachometer signal by f/v (frequency to voltage) conversion. Encoder tachometer mode gives the widest speed useable speed range and fastest velocity-loop response. Use Hall-tachometer mode for high-speed operation where no encoder feedback exists. Example: a 4-pole brushless motor with a 500 line encoder operating at 1500 rpm. The f/v clock pulse rate is 50,000 Hz for encoder feedback, and 300 Hz for Hall feedback. As speed drops, ripple will increase. At a standstill, there will be no feedback between Hall or encoder transitions, resulting in jitter. This may be acceptably small for an encoder application, or unacceptably rough for a Hall tach. Use the /Enable or /Brake inputs to disable the amplifier if zero-output is required.

### Maximum f/v pulse rate

An f/v clock signal is generated that is 4X the encoder line frequency. The maximum f/v clock rate is 600kHz. First check to make sure that your f/v clock will be in limits.

$$f/v \text{ Encoder} = \frac{\text{Lines} \times \text{rpm}}{15}$$

$$f/v \text{ Hall} = \frac{\text{Poles} \times \text{rpm}}{20}$$

If the rate is greater than 600kHz, then maximum rpm must be reduced. If the rate is acceptable, select the f/v capacitor CH23 as follows:

### Hall tachometer

Set DIP switches S2 & S3 ON. Choose CH23 based on this equation:

$$C = \frac{1400}{\text{Poles} \times \text{rpm}} \quad (C = \text{CH23 in } \mu\text{F})$$

### Encoder tachometer

Set DIP switches S2 and S3 OFF. Choose CH23 based on this equation:

$$C = \frac{1 \times 10e9}{\text{Lines} \times \text{rpm}} \quad (\text{CH23} = \text{pF})$$

Choose a capacitor with the closest value. This should produce a tach-voltage of about  $\pm 5V$  at the rpm used in the equations. With the default value of 49.9k for RH22 (feedback scaling header resistor), this would correspond to the maximum reference input of  $\pm 10V$ .

### Low-pass filter

The choice of low-pass filter will determine both the useable rpm range of the f-v converter and the effective response time of the velocity-loop ( or effective bandwidth ). For widest speed range, set the low-pass filter frequency to a lower value. For faster response times ( higher velocity loop bandwidth ) set the frequency to a higher value.

Because Hall pulse rates will typically be as much as 100X less than encoder pulse rates, a low-pass filter frequency that gives satisfactory results at lower speeds may noticeably slow down the step response of the motor. The default filter frequency is 16Hz for Hall tach operation.

This gives a frequency of 159Hz, which is a good starting point for many motors. CH24 & CH25 may be removed for fastest response and best stiffness with smaller motors. In general, use the lowest frequency possible that does not begin to slow down the response of the loop to a step input. This will give the widest rpm range.

### Velocity loop tuning

Begin with S1 ON (integrator disabled), REF GAIN pot fully CW, TACH GAIN and LOOP GAIN pots fully CCW. Previous steps must be performed to insure that motor is properly phased and rotates smoothly in both directions.

### Static Setup

Apply a  $\pm 10V$  signal to Ref inputs Measure feedback voltage at J3-4 This should be about  $\pm 5V$  if CH23 has been chosen correctly. Motor rpm can be measured by viewing any Hall signal and calculating as follows:

$$RPM = \frac{120}{Th \times \text{Poles}}$$

Where *Th* is the *period* of one Hall signal (U, V, or W ).

### Dynamic Setup

Set switch S1 ON (integrator disabled). Use a function generator with a square wave output set to a small voltage ( $\pm 0.5V$ ). Connect to reference inputs and adjust frequency so that motor can change direction and settle to a set speed (1 Hz). Connect oscilloscope to J3-4 to monitor voltage. If possible, also connect to J2-10, current monitor. Adjust Loop Gain pot for fastest response that does not produce oscillation or excessive ringing of either tach signal, or current monitor.

When Loop Gain is adjusted, set S1 OFF. Adjust *Integ Freq* pot CW until overshoot on tach signal rings and then back off for stable response. CW adjustment increases stiffness (speed stability), but too much will produce oscillation. With Loop Gain and Integ Freq adjusted properly, response to step inputs will be smooth, and free from oscillation.

### FEEDBACK POLARITY

Jumper J1-B switches the polarity of the feedback signal. Once the amplifier is adjusted in torque mode to compensate for load inductance, the velocity loop is closed by setting DIP switches 2 & 3 to one of the three possible choices: Hall, encoder, or output voltage. If the initial setting produces run-away (positive feedback), disable the amplifier and set the jumper to the alternate position. This should produce a stable velocity loop which can then be 'tuned' using the potentiometers.

### VOLTAGE FEEDBACK MODE

Set DIP switches S1 OFF, S2 ON, and S3 OFF. Set Ref Gain pot fully CW, Tach Gain, Loop Gain, and Integ Freq pots fully CCW. With the default components, the voltage gain is X40. Thus, a 5V input will produce a 200V-output voltage swing.

# MODELS 5224AC, 5424AC LINE-POWERED DC BRUSHLESS SERVO AMPLIFIER

## CONTINUOUS CURRENT LIMIT SET

Control of the peak current limits can be made externally via connector pin J3-21. A resistor can be connected between this pin and signal ground (J3-12, 13, 15, or 16), or the pin can be driven by a voltage between 0 and +5VDC. Using this technique, the current limit can be controlled over a range of 10% TO 100% of the amplifiers rated continuous current. The figure below shows the circuit. RH14 internal.

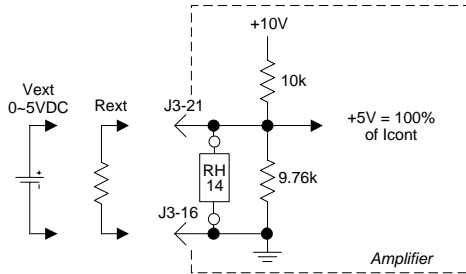

The table below lists values for Vext and Rext to control the continuous current limit externally.

Icont	Rext	Vext
10	<out>	4.9
9	30k	4.29
8	15k	3.66
7	7.5k	3.0
6	4.7k	2.4
5	2.7k	1.78
4	1.5k	1.16
3	560	0.54
2.1	0	0

These values will give results within 10%, typically. For greater accuracy, measure Current Ref signal, and select parts for desired value.

## MOTOR INDUCTANCE SETTING

Header components RH20, CH18, and CH16 control the amplifier compensation for different motors. These set the gain in the current error amplifier to give the best response for different winding inductances.

The tables below give values for the header parts for the two models. If the inductance of your motor is less than 1/2 of the value shown in the table, use the values from the next lower inductance range. E.g., for a 4mH motor, use the values from the 3 mH row (1/2 of 10mH is 5mH, which is greater than 4mH, so the value from the next lower row, 3mH, is used).

**For all tables, CH18 is 15nF, and CH16 is <out>.**

**Model 5224AC @ 115VAC**

L (mH)	RH20 (k )
0.3	10
<b>I</b>	<b>30</b>
3	100
10	300
30	1 Meg

**Model 5424AC @ 230VAC**

L (mH)	RH20 (k )
0.3	4.7
<b>I</b>	<b>15</b>
3	47
10	150
30	470

**Model 5424AC @ 115VAC**

L (mH)	RH20 (k )
0.3	10
1	30
3	100
10	300
30	1 Meg

## SIGNAL BOARD AND HEADER SOCKET LAYOUT

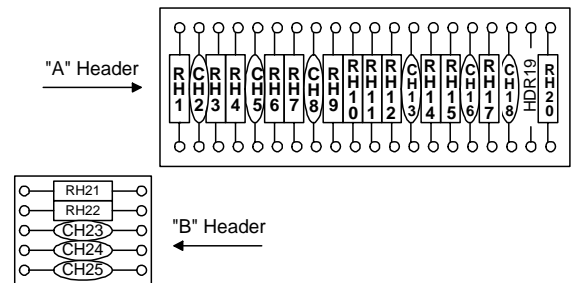
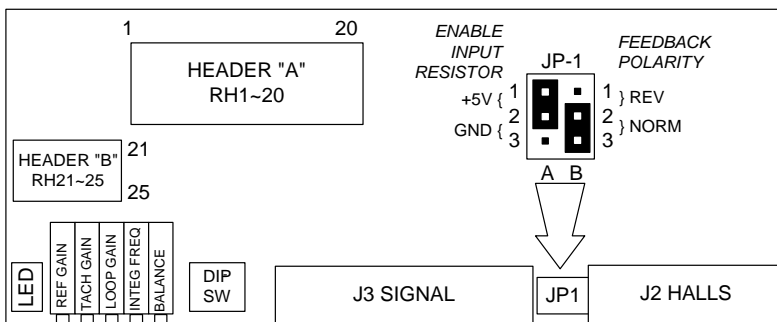

The A and B header sockets hold the components that determine the amplifiers performance such as operating mode, current limits, and feedback type. Components are named **RHn**, **CHn** as Resistor Header n, Capacitor Header n, etc. The table above lists values that cover a wide range of motor winding inductances. Note: RH22 is temporarily installed in the RH19 position as default from factory. For velocity operation, after current mode commutation is verified working, install RH22.

## SETTING LOAD INDUCTANCE COMPENSATION

Header components RH20, CH18, and CH16 control the frequency response of the *current error amplifier*. Determining the correct values for these parts with your motor is called *tuning the current loop*, or setting the inductance compensation for the amplifier.

This proceeds in two parts: adjustment of the DC gain in the current error amplifier, and adjustment of the integrator frequency. Header component RH20 controls the DC gain, and is selected with CH18 replaced by a jumper. When this is complete, CH18 is re-installed, and the best value is then selected. In most applications, CH16 is not needed, but can be added to lower the high-frequency response.

*Important: always power-down when changing components in the header socket.*

### DC gain adjustment (RH20)

1. Use a square-wave reference signal of  $\pm 0.5V$ , 50Hz.. Set the power supply to the anticipated operating voltage.
2. Replace the compensation capacitor (CH18) with a short (jumper)
3. Observing the signal at the current monitor, pick a value for RH20 that gives a clean step response. Do not consider the 'flat-top' portion of the waveform, the 'tilt' will disappear when CH18 is adjusted.

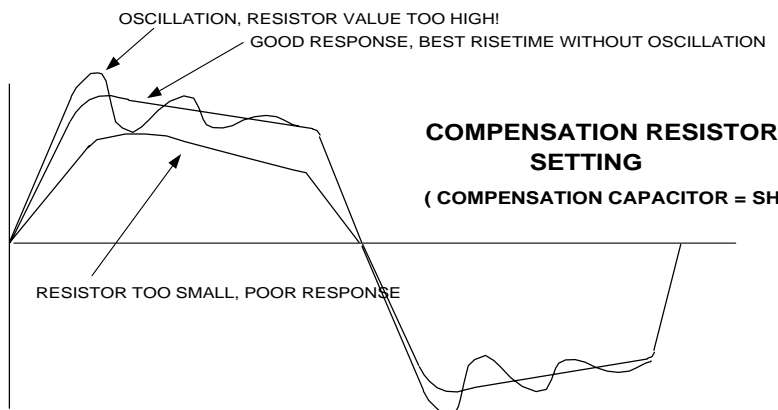

### INTEGRATOR adjustment (CH18)

1. Begin with the default value of 15nF. Check step waveform. If overshoot  $>10\%$  and ringing occur, CH18 is too small. If response is sluggish, CH18 is too big. When changing CH18, use a factor of 3X (or 1/3) to see significant effect. Thereafter-smaller changes can be used to converge on best setting.
2. When CH18 is properly chosen, some overshoot ( $<10\%$ ) will occur, but waveform will settle cleanly to a 'flat-top' with little undershoot.

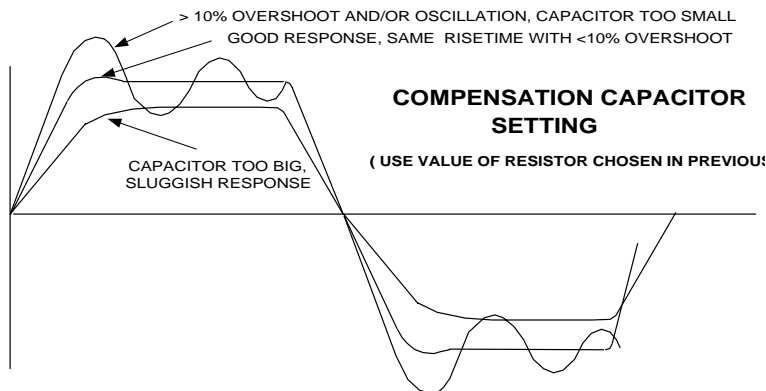

## BANDWIDTH TESTING

1. Change reference signal to sinusoidal waveform. Begin at 100Hz, adjust amplitude for a 0.35V peak-to-peak waveform at the current monitor. This should be seven vertical divisions on an oscilloscope that is set to 0.05V/division.
2. Sweep the frequency upward. When the peak-to-peak amplitude drops to 5 divisions this is the  $-3dB$  frequency. This method will permit testing of 10mH loads to 3kHz BW at 120VAC or a 20mH load to 3kHz at 240VAC. For higher inductance values, slew rate limiting will force p-p current amplitude to be lowered for observation without error.

# MODELS 5224AC, 5424AC

## LINE-POWERED DC BRUSHLESS SERVO AMPLIFIER

### OUTLINE DIMENSIONS

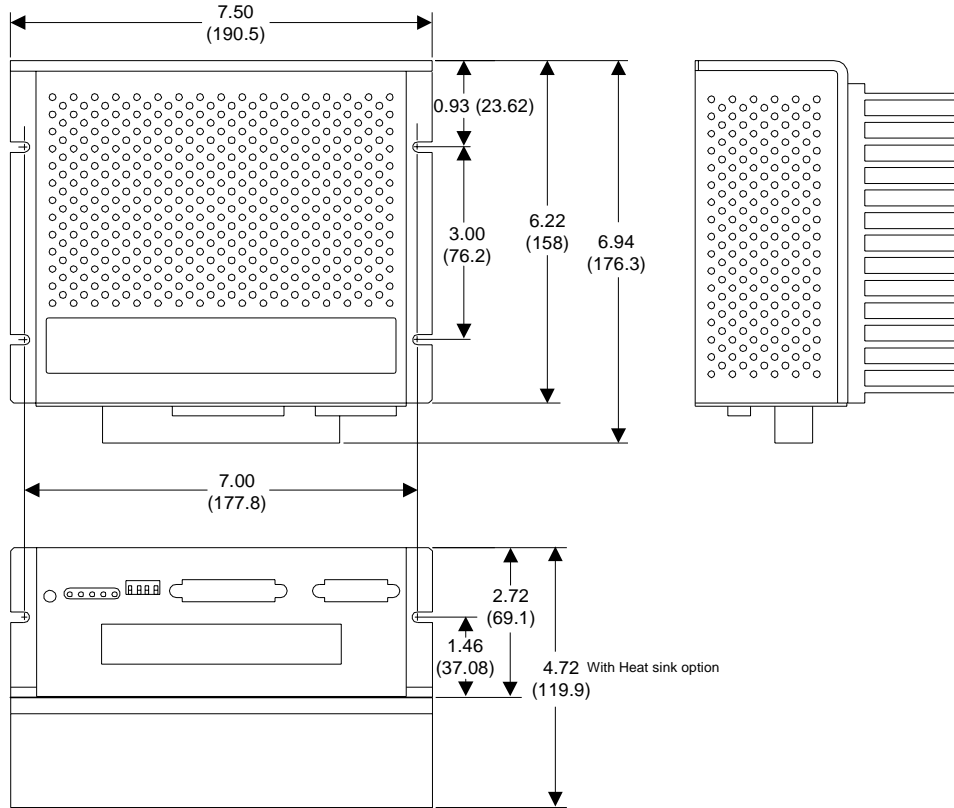

*Dimensions in inches (mm.)*

- WEIGHT** 3.71 lb. (1.69 kg) without optional heatsink. Add 3.2 lb. (1.47 kg) for heatsink.
- CONNECTORS** J1: Power & motor 9-position barrier strip; #6-32 screws have wire protector washers  
 J2: Motor signal 15 position female sub-D type; with #4-40 standoffs for cable shell  
 J3: Control Signal 25 position female sub-D type; with #4-40 standoffs for cable shell

### ORDERING GUIDE

Model 5224AC	20A peak, 10A continuous, 115VAC, 50/60Hz nominal input power
Model 5424AC	20A peak, 10A continuous, 115/230VAC, 50/60Hz nominal input power

Notes: Add "H" to model number to specify heatsink option.  
 Example: Model 5424AC with heatsink would be ordered as a 5424ACH

No user serviceable parts. Contact Copley for service.

### OTHER BRUSHLESS AMPLIFIERS

- 7000 Series** Five different model types for driving AC brushless motors with sinusoidal commutation using a variety of feedback and control card schemes
- 5xx1 Series** Six models operating from +24 to +225VDC, 10~30A peak, 5~15A continuous. CE compliance available (5xx1CE models), Hall/encoder velocity feedback option. Brushless tachometer option.
- Model 503** Torque-mode brushless amplifier. +18 to +55VDC, 5A continuous, 10A peak.

