

EDGE FILTERS MODEL FL1, FL2

PRODUCT DESCRIPTION

Edge filters are used to greatly reduce the electrical noise from the power cabling that connects PWM amplifiers to their loads.

The output of Copley DC analog families of PWM amplifiers are sharp-edged voltage waveforms to their loads. Typically, the output voltage from an amplifier will switch from zero to the supply voltage, or from the supply voltage to zero, in .2 microseconds. This fast switching is desirable in a PWM amplifier because the faster the switching, the smaller the switching losses in the amplifier.

But fast voltage transitions to motor or other loads can create three kinds of problems:

- 1) Signal wires running beside the power wiring can pick up noise. Usually the coupling mechanism into adjacent wires is capacitive. Evidence of this is seen as positive and negative voltage spikes mixed in with the signals. This can happen even if one uses shielded power cabling because the fast-rising voltages in the power wiring can couple capacitively to the shield causing the shield itself also to have moderately fast rise-time spikes on it, which then couple into the signal wiring.
- 2) Fast-rising voltages can couple from the motor windings to the encoder or resolver mounted on the motor or close to the motor. The coupling mechanism is usually capacitive from the motor windings through the motor frame into the sensor but it can also be inductive, coupling through the motor's magnetic paths to the encoder or resolver.
- 3) Signal wiring and sensors further away from the power wiring can also be affected by radiated electromagnetic interference. This is usually not a serious problem with shielded power wiring.

Each of these three effects is reduced greatly by slowing up the rate of rise of

the voltage waveforms from the amplifier. An edge filter is designed to operate on the voltage transitions or edges of the voltage waveforms as shown in (Fig. 1)

Note that the voltage applied to the motor still has a chopped, pulse-width-modulated characteristic, but the rise times and fall times of the voltage transitions are simply much longer. The rise time is increased from about .2 microseconds to about 5 microseconds by the 100 kHz filters. The schematic of the filter circuit is shown below. On each side, the circuit is basically a series inductor with a capacitor to ground; however, in parallel with the capacitor to ground there is a simple damping network consisting of another capacitor and a resistor. Even with the damping network there is still some overshoot in the voltage waveform from the filter.

Because the resonant frequency of the filter is more than four times higher than the switching frequency used in the amplifier, the addition of the filter should have a negligible effect on the dynamics of the amplifier of the servo loop in which the amplifier is used. The filter looks to the amplifier like only an added inductance in series with the motor. The amount of the total added inductance is shown in the table for each filter as ADDED L. If the minimum inductance required for a particular amplifier at a particular operating voltage is not provided by the motor that has been selected, then the filter inductance can be used to help make up the need minimum inductance. In most cases no additional inductance will be needed.

OUTLINE DIMENSIONS

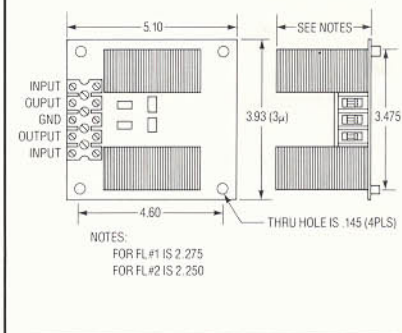

KEY SPECIFICATIONS

MODEL	MODEL FL1	MODEL FL2
VOLTAGE, max	175 V	80 V
CURRENT, maximum RMS	60A 30A	20A 12A
RESONANT FREQ.	100 kHz	100 kHz

ORDERING GUIDE

MODEL	DESCRIPTION
FL1	Edge filter
FL2	Edge filter

INDUCTORS

Most all of the PWM amplifier designed by Copley require a minimum output inductance in series with the load.

Contact Copley for design recommendations.

Sold by Servo Systems Co. 115 Main Road, P.O. Box 97, Montville, NJ 07045-0097
Toll Free: (800) 922-1103 Phone: (973) 335-1007 Fax: (973) 335-1661
www.servosystems.com

FUNCTIONAL DIAGRAM

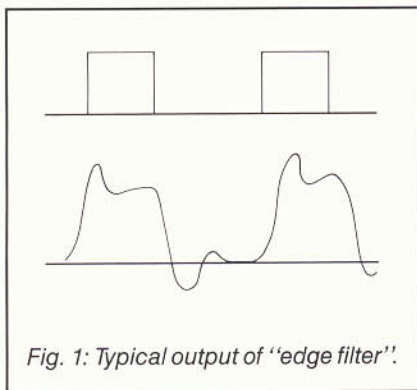
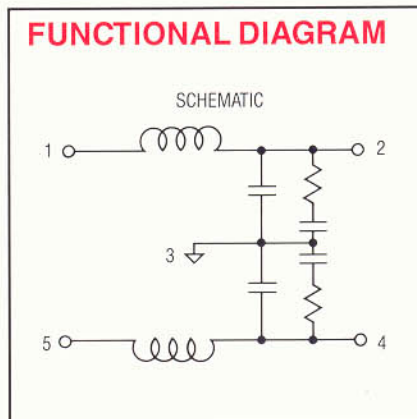

Fig. 1: Typical output of "edge filter".