

Series A58 Absolute – Parallel Output



- **Single or Multi-turn versions**
- **Resolution up to 14 Bit (single turn) and 24 Bit (multi-turn)**
- **Parallel output**
- **Short Circuit Protected**

As machine position control systems strive for higher and higher performance, being able to incorporate a feedback device which provides exact position data can be of substantial benefit. Dynapar brand Series A58 encoders provide a unique data output for each resolvable shaft position. By using absolute position rather than incremental count data, the shaft position can always be known, even after power interruptions or in the presence of electrical noise. System design can be simplified because there is no need to perform a reference cycle or return to home function to determine the true machine position.

Single turn devices are offered with resolution ranging from .5° (720 counts per rev) to 14 bit (16,384 counts per rev). For applications which require travel over extended distances, multi-turn models can provide unique position outputs for each shaft position up to 4096 rotations.

Parallel output formats are available in binary or gray code.

SPECIFICATIONS

Mechanical

- Shaft Size:** 6mm syncro flange, 10 mm clamping flange
- Shaft Loading:** 10 mm: 24 lbs axial, 35 lbs radial; 6 mm: 13 lbs axial, 24 lbs radial
- Shaft Tolerance:** +0/-0.0007
- Starting Torque:** ≤0.2 in-oz
- Weight:** 11 oz. (300 g.)
- Shaft Speed:** 6,000 RPM

Environmental

- Operating Temperature:** -25° to 85°C
- Storage Temperature:** -25° to +85°C
- Shock:** 100 G's for 3 msec duration
- Vibration:** 10 to 500 Hz @ 10 G's
- Enclosure Rating:** IP67

Electrical - Parallel Outputs

- Accuracy** ± 1/2 LSB (± 1 LSB above 12 bit)
- Power Requirements:** 5 VDC ±5% or 10-30V; 200 mA maximum
- Code:** Absolute; natural binary or Gray Code
- Data Output:** ±30 mA, short circuit protected
- Control Inputs:** Active low, ≤20% of $V_{(IN)}$; Inactive high, open or ≥70% of $V_{(IN)}$
- Latch Input:** Data outputs change with shaft position when high or open; data outputs inhibited from changing when low. Available only for models with 12 bit and below resolution
- Direction Input:** Count up for CW shaft rotation when high or open; count down for CW shaft rotation when low. Available only for models with 13 bit and below resolution
- Frequency Response:** 100 kHz maximum

Electrical Connections

Table 1 – Single Turn

14 bit	13 Bit	12 Bit	10 Bit	Color
S0 (LSB)	N.C.	N.C.	N.C.	Grey/Pink
S1	S0 (LSB)	N.C.	N.C.	Brown/Yellow
S2	S1	S0 (LSB)	N.C.	Brown/Grey
S3	S2	S1	N.C.	Red/Blue
S4	S3	S2	S0 (LSB)	Violet
S5	S4	S3	S1	White/Brown
S6	S5	S4	S2	White/Green
S7	S6	S5	S3	White/Yellow
S8	S7	S6	S4	White/Grey
S9	S8	S7	S5	White/Pink
S10	S9	S8	S6	White/Blue
S11	S10	S9	S7	White/Red
S12	S11	S10	S8	White/Black
S13(MSB)	S12(MSB)	S11(MSB)	S9 (MSB)	Brown/Green
Tristate				Yellow
Latch (binary only)				Pink
Direction				Green
Common				Black
5 V/10-30 VDC				Red
Alarm				Brown

Table 2 – Multi-Turn

Signal	Color	Pin	Signal	Color	Pin
S0	Brown	2	M4	White/Blue	14
S1	Green	21	M5	Brown/Blue	33
S2	Yellow	3	M6	White/Red	15
S3	Grey	22	M7	Brown/Red	34
S4	Pink	4	M8	White/Black	16
S5	Violet	23	M9	Brown/Black	35
S6	Grey/Pink	5	M10	Grey/Green	17
S7	Red/Blue	24	M11	Yellow/Grey	36
S8	White/Green	6	Alarm	Pink/Green	18
S9	Brown/Green	25	Direction	Yellow/Pink	10
S10	White/Yellow	7	Latch	Green/Blue	30
S11	Yellow/Brown	26	Enable	Yellow/Blue	12
M0	White/Grey	8	10-30 VDC	Red	13
M1	Grey/Brown	27	10-30 VDC	White	31
M2	White/Pink	9	Common	Blue	1
M3	Pink/Brown	28	Common	Black	20

A58 Housing Dimensions (less mount)

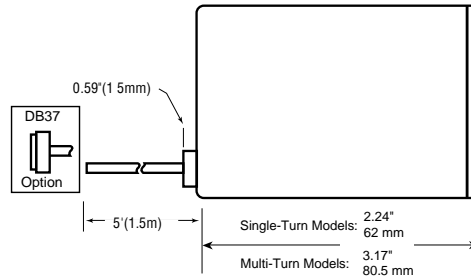

A58 Mount Dimensions (less housing)

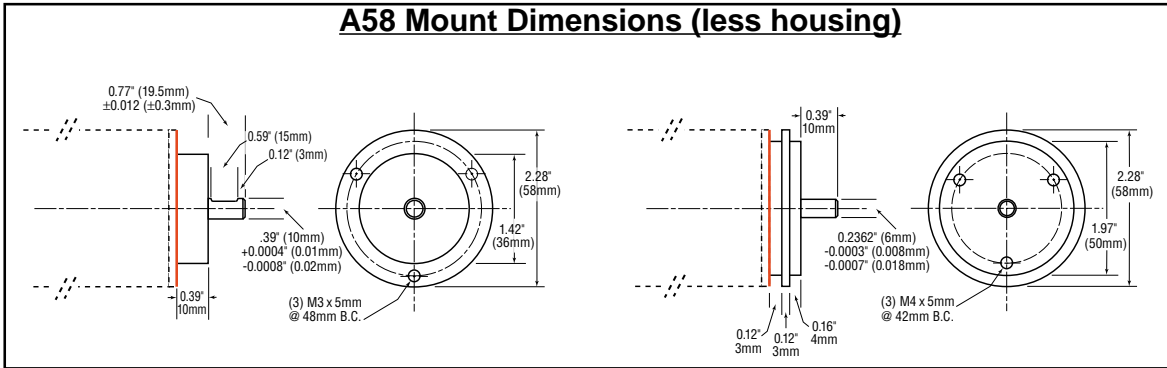

Ordering Information

To order, complete the model number with code numbers from the table below:

Code 1: Model	Code 2: CPR	Code 3: Mechanical	Code 4: Interface	Code 5: Electrical	Code 6: Termination
A58	<input type="checkbox"/>	<input type="checkbox"/>	<input type="checkbox"/>	<input type="checkbox"/>	<input type="checkbox"/>
Ordering Information					
A58 58mm Absolute encoder, Parallel Output	0720 720 counts/rev** 1024 1024 counts/rev (10 bit) 4096 4096 counts/rev (12 bit) 8192 8192 counts/rev(13 bit) 0014 16,384 counts/rev (14 bit) 1212 4096 counts/rev, multiturn (24 bit)	0 Face mount 10mm shaft 1 Servo mount 6mm shaft	0 Parallel-Binary (push-pull) 1 Parallel-Gray code (push-pull)	0 5 VDC input power 1 10 - 30 VDC input power (must be ordered for multi-turn models*)	0 End Exit Cable 2 End exit cable w/ DB37 male connector (must be ordered for multi-turn models*)

* Code 2: 1024, 4096, 8192, 0014 = single-turn
1212 = multi-turn

** Utilizes excess gray code

Series A58 Absolute – Bus Output



- **Single or Multi-turn versions**
- **Resolution up to 14 Bit (single turn) and 26 Bit (multi-turn)**
- **Choice of 3 bus networks**
- **Short Circuit Protected**

As machine position control systems strive for higher and higher performance, being able to incorporate a feedback device which provides exact position data can be of substantial benefit. Dynapar brand Series A58 encoders provide a unique data output for each resolvable shaft position. By using absolute position rather than incremental count data, the shaft position can always be known, even after power interruptions or in the presence of electrical noise. System design can be simplified because there is no need to perform a reference cycle or return to home position to determine the true machine position.

Single turn devices are offered with resolution ranging from .5° (720 counts per rev) to 14 bit (16,384 counts per rev). For applications which require travel over extended distances, multi-turn models can provide unique position outputs for each shaft position up to 4096 rotations.

Choice of bus network which can significantly reduce wiring, enhance diagnostics and reduce total installed cost.

Electrical - DeviceNet

Accuracy: $\pm 1/2$ LSB (± 1 LSB above 12 bit)

Power Requirements: 10 - 30 VDC;
200 mA maximum

Code: Binary

Current for feed through supply: 3 Amp

Interface: CAN High Speed per ISO/DIS
11898, CAN specification 2.0 B

Protocol: DeviceNet according to Rev. 2.0
programmable encoder

Update Rate: 5 ms

Baud Rate: DIP switch selectable 125, 250,
500 Kbps

MAC ID: DIP switch settable

Electrical - Profibus

Accuracy $\pm 1/2$ LSB (± 1 LSB above 12 bit)

Power Requirements: 10 - 30 VDC
200 mA maximum

Code: Binary

Current for feed through supply: 2 Amp

Interface: RS-485

Protocol: Profibus DP w/class 2 encoder
profile

Baud Rate: Automatically set by master
between 9.6 Kbps and 12 Mbps

Device Address: DIP switch settable

Programmable Functions: direction,
resolution per rev, total resolution, preset

Electrical - Interbus

Accuracy: $\pm 1/2$ LSB (± 1 LSB above 12 bit)

Power Requirements: 10 - 30 VDC
200 mA maximum

Code: Binary

Interface: RS-485 for remote bus

Protocol: Interbus w/ ENCOM profile K3

Update Rate: 600 μ s

Baud Rate: 500 Kbps

Programmable functions: direction, scaling
factor, preset, offset

SPECIFICATIONS

Mechanical

Shaft Size: 6mm syncro flange, 10 mm
clamping flange

Shaft Loading: 10 mm: 24 lbs axial, 35 lbs
radial; 6 mm: 13 lbs axial, 24 lbs radial

Shaft Tolerance: +0/-0.0007

Starting Torque: ≤ 0.2 in-oz

Weight: 11 oz. (300 g.)

Shaft Speed: 6,000 RPM

Environmental

Operating Temperature: -25° to +85°C

Storage Temperature: -25° to +85°C

Shock: 100 G's for 3 msec duration

Vibration: 10 to 500 Hz @ 10 G's

Enclosure Rating: IP67

A58 Housing Dimensions (less mount)

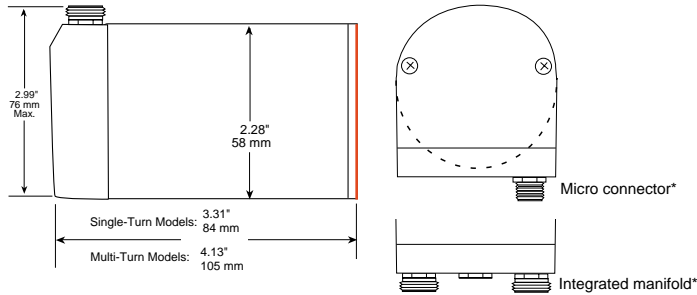

*** Industrial Bus Interfaces**

Micro Connector: Simple plug-in connection from a "T" drop off the DeviceNet trunk line

Integrated Manifold: Provides direct in and out connection to bus trunk line

A58 Mount Dimensions (less housing)

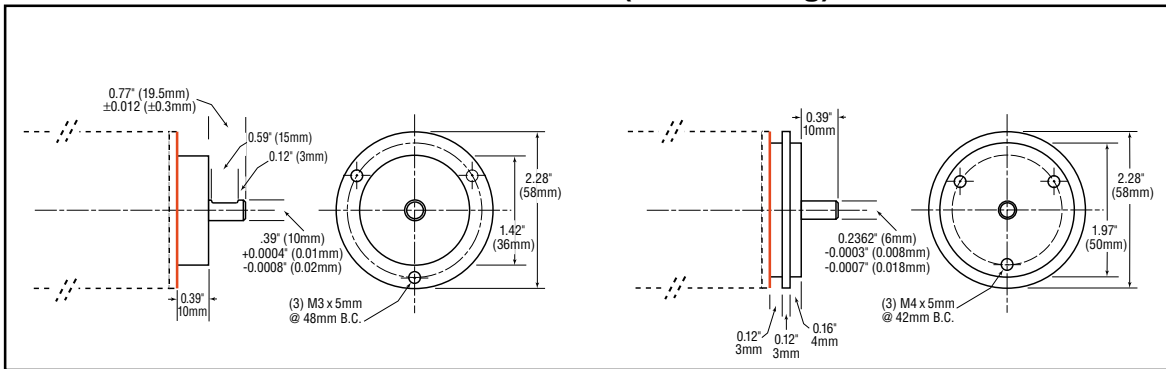

Ordering Information

To order, complete the model number with code numbers from the table below:

Code 1: Model	Code 2: CPR	Code 3: Mechanical	Code 4: Interface	Code 5: Electrical	Code 6: Termination	
A58	<input type="checkbox"/>	<input type="checkbox"/>	<input type="checkbox"/>	<input type="checkbox"/>	<input type="checkbox"/>	
Ordering Information						
A58 58mm Absolute encoder	1024	1024 counts/rev (10 bit)	0 Face mount 10mm shaft	D DeviceNet P Profibus I Interbus	1 10 - 30 VDC input power	M Integrated bus manifold
	4096	4096 counts/rev (12 bit)	1 Servo mount 6mm shaft			available when code 4 = D
	8192	8192 counts/rev (13 bit)				E 5 pin Micro connector †
	0014	16,398 counts/rev (14 bit)				
	1212	4096 counts/rev, multiturn (24 bit)				
	1213	8192 counts/rev, multiturn (25 bit)				
1214	16,384 counts/rev, multiturn (26 bit)					
Accessories						
ACAB-F90MS1	5 pin DeviceNet cable, female 90°, male straight, 1 meter, Micro connector					
ACAB-F90MS2	5 pin DeviceNet cable, female 90°, male straight, 2 meters, Micro connector					
ACAB-F90FS1	5 pin DeviceNet cable, female 90°, female straight, 1 meter, Micro connector					
ACAB-F90FS2	5 pin DeviceNet cable, female 90°, female straight, 2 meters, Micro connector					
ACON-MFF	DeviceNet splitter, male, female, female					