

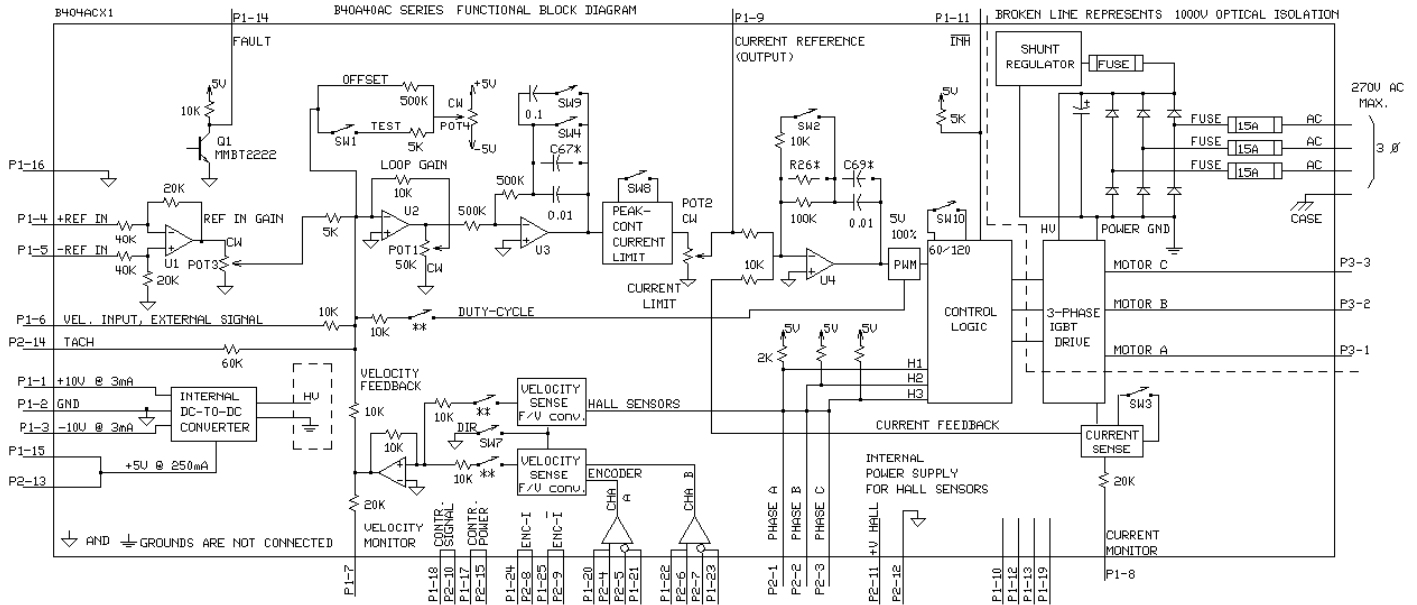

**BLOCK DIAGRAM**





MODE SELECTION

|                   | SW2 | SW4 | SW5 | SW6 | ENC  | TACH |
|-------------------|-----|-----|-----|-----|------|------|
| CURRENT MODE      | ON  | ON  | OFF | OFF | NC   | NC   |
| HALL VELOCITY     | ON  | OFF | OFF | ON  | NC   | NC   |
| ENCODER VELOCITY  | ON  | OFF | ON  | ON  | CONN | NC   |
| DUTY CYCLE MODE   | ON  | OFF | ON  | OFF | NC   | NC   |
| EXTERNAL VELOCITY | ON  | OFF | OFF | OFF | NC   | CONN |

NC-NOT CONNECTED, CONN-CONNECTED

LED GREEN - NORMAL OPERATION, LED RED- FAULT  
 RECOMMENDED SETTING FOR CURRENT MODE - POT1 FULLY CCW, POT3 FULLY CW  
 AMPLIFIERS ARE SHIPPED IN CURRENT MODE WITH MAXIMUM CURRENT SETTINGS  
 SW9 MUST BE ON FOR PROPER OPERATION IN HALL VELOCITY MODE  
 FOR OTHER SWITCH FUNCTIONS SEE SWITCH DESCRIPTION  
 \* OPTIONAL USER INSTALLED THROUGH HOLE COMPONENTS  
 \*\* THESE MODE FUNCTIONS ARE CONTROLLED BY COMBINATIONS OF SW5 AND SW6.

**Information on Approvals and Compliances**

|   |   |
|---|---|
|  | <p>US and Canadian safety compliance with UL 508c, the industrial standard for power conversion electronics. UL registered under file number E140173. Note that machine components compliant with UL are considered UL registered as opposed to UL listed as would be the case for commercial products.</p>           |
|  | <p>Compliant with European CE for both the Class A EMC Directive 2004/108/EC on Electromagnetic Compatibility (specifically EN 61000-6-4:2007 and EN 61000-6-2:2005) and LVD requirements of directive 2006/95/EC (specifically EN 60204-1:2006), a low voltage directive to protect users from electrical shock.</p> |
|  | <p>RoHS (Reduction of Hazardous Substances) is intended to prevent hazardous substances such as lead from being manufactured in electrical and electronic equipment.</p>  |

**SPECIFICATIONS**

| Power Specifications                                |         |  |
|---|---------|--|
| Description   | Units   | Value  |
| AC Supply Voltage Range                             | VAC     | 45 - 265   |
| DC Supply Voltage Range                             | VDC     | 60 - 400   |
| DC Bus Over Voltage Limit                           | VDC     | 420  |
| Maximum Peak Output Current <sup>1</sup>            | A       | 40   |
| Maximum Continuous Output Current                   | A       | 20   |
| Maximum Continuous Output Power                     | W       | 7600   |
| Maximum Power Dissipation at Continuous Current     | W       | 400  |
| Internal Bus Capacitance                            | µF      | 2970   |
| Internal Shunt Resistance                           | Ω       | 20   |
| Internal Shunt Resistor Power Rating                | W       | 100  |
| Internal Shunt Resistor Turn-on Voltage             | VDC     | 390  |
| Minimum Load Inductance (Line-To-Line) <sup>2</sup> | µH      | 600  |
| Low Voltage Supply Outputs                          | -       | ±10 VDC (3 mA), +5 VDC (250 mA), +6 VDC (30 mA)  |
| Switching Frequency                                 | kHz     | 20   |
| Shunt Fuse  | A       | 3  |
| Bus Fuse  | A       | 15   |
| Control Specifications                              |         |  |
| Description   | Units   | Value  |
| Command Sources                                     | -       | ±10 V Analog   |
| Feedback Supported                                  | -       | Halls, Incremental Encoder, Tachometer (±60 VDC)   |
| Commutation Methods                                 | -       | Trapezoidal  |
| Modes of Operation                                  | -       | Current, Hall Velocity, Duty Cycle, Velocity   |
| Motors Supported                                    | -       | Single Phase (Brushed, Voice Coil, Inductive Load), Three Phase (Brushless)  |
| Hardware Protection                                 | -       | Invalid Commutation Feedback, Over Current, Over Temperature, Over Voltage, Short Circuit (Phase-Phase & Phase-Ground) |
| Primary I/O Logic Level                             | -       | 5V TTL   |
| Internal Shunt Regulator                            | -       | Yes  |
| Internal Shunt Resistor                             | -       | Yes  |
| Mechanical Specifications                           |         |  |
| Description   | Units   | Value  |
| Agency Approvals                                    | -       | CE Class A (EMC), CE Class A (LVD), cUL, RoHS, UL  |
| Size (H x W x D)                                    | mm (in) | 234.7 x 163.7 x 114.2 (9.2 x 6.4 x 4.5)  |
| Weight  | g (oz)  | 3100 (109.3)   |
| Heatsink (Base) Temperature Range <sup>3</sup>      | °C (°F) | 0 - 65 (32 - 149)  |
| Storage Temperature Range                           | °C (°F) | -40 - 85 (-40 - 185)   |
| Form Factor   | -       | Panel Mount  |
| P1 Connector  | -       | 25-pin, female D-sub   |
| P2 Connector  | -       | 15-pin, female D-sub   |
| P3 Connector  | -       | 3-contact, 11.10 mm spaced, tri-barrier terminal block   |
| P4 Connector  | -       | 4-contact, 11.10 mm spaced, tri-barrier terminal block   |

**Notes**

1. Maximum duration of peak current is ~2 seconds. Peak RMS value must not exceed continuous current rating of the drive.
2. Lower inductance is acceptable for bus voltages well below maximum. Use external inductance to meet requirements.
3. Additional cooling and/or heatsink may be required to achieve rated performance.

**PIN FUNCTIONS**

| P1 - Signal Connector |                  |  |      |
|-----------------------|------------------|--|------|
| Pin                   | Name             | Description / Notes  | I/O  |
| 1                     | +10V 3mA OUT     | ±10 V @ 3 mA low power supply for customer use. Short circuit protected. Reference ground common with signal ground.   | O    |
| 2                     | SIGNAL GND       |  | SGND |
| 3                     | -10V 3mA OUT     |  | O    |
| 4                     | +REF IN          | Differential Reference Input (±10 V Operating Range, ±15 V Maximum Input)  | I    |
| 5                     | -REF IN          |  | I    |
| 6                     | VEL INPUT        | Single ended reference input for external velocity signal, range ±10 V (maximum ±15 V).  | I    |
| 7                     | VEL MONITOR OUT  | Velocity Monitor. Analog output proportional to motor speed. In Encoder Velocity mode, output is proportional to the encoder line frequency. In Hall Velocity mode, output is proportional to the electrical cycle frequency. Encoder Velocity scaling is 25 kHz/V. Hall Velocity scaling is 100 Hz/V. | O    |
| 8                     | CURR MONITOR OUT | Current Monitor. Analog output signal proportional to the actual current output. Scaling is 5.7 A/V by default but may be reduced to half this value by setting DIP switch SW-3 to OFF (see Hardware Settings section below). Measure relative to signal ground.                                       | O    |
| 9                     | CURR REF OUT     | Measures the command signal to the internal current-loop. This pin has a maximum output of ±7.25 V when the drive outputs maximum peak current. Measure relative to signal ground.   | O    |
| 10                    | RESERVED         | Reserved   | -    |
| 11                    | INHIBIT IN       | TTL level (+5 V) inhibit/enable input. Leave open to enable drive. Pull to ground to inhibit drive. Inhibit turns off all power devices.   | I    |
| 12                    | RESERVED         | Reserved   | -    |
| 13                    | RESERVED         | Reserved   | -    |
| 14                    | FAULT OUT        | TTL level (+5 V) output becomes high when power devices are disabled due to at least one of the following conditions: inhibit, invalid Hall state, output short circuit, over voltage, over temperature, power-up reset.   | O    |
| 15                    | +5V @ 250mA      | ±5 V @ 250 mA low power supply for customer use. Short circuit protected. Referenced to signal ground.   | O    |
| 16                    | SIGNAL GND       | Signal Ground  | SGND |
| 17                    | CTLR POWER       | Controller Power. Pass-through to Port 2 (P2) for customer use.  | I/O  |
| 18                    | CTLR SIGNAL      | User Controller Signal. Pass-through to Port 2 (P2) for customer use.  | I/O  |
| 19                    | RESERVED         | Reserved   | -    |
| 20                    | ENC CH A+        | Differential Encoder Channel A Output. Pass-through from Port 2 (P2).  | O    |
| 21                    | ENC CH A-        |  | O    |
| 22                    | ENC CH B+        | Differential Encoder Channel B Output. Pass-through from Port 2 (P2).  | O    |
| 23                    | ENC CH B-        |  | O    |
| 24                    | INDEX+           | Differential Encoder Index Output. Pass-through from Port 2 (P2).  | O    |
| 25                    | INDEX-           |  | O    |

| P2 - Feedback Connector |             |   |      |
|-------------------------|-------------|---|------|
| Pin                     | Name        | Description / Notes   | I/O  |
| 1                       | HALL 1      | Single-ended Hall/Commutation Sensor Inputs (+5 V logic level)  | I    |
| 2                       | HALL 2      |   | I    |
| 3                       | HALL 3      |   | I    |
| 4                       | ENC. CH. A+ | Differential Encoder Channel A Input (+5 V Logic Level)   | I    |
| 5                       | ENC. CH. A- |   | I    |
| 6                       | ENC. CH. B+ | Differential Encoder Channel B Input (+5 V Logic Level)   | I    |
| 7                       | ENC. CH. B- |   | I    |
| 8                       | INDEX+      | Differential Encoder Index Input (+5 V Logic Level)   | I    |
| 9                       | INDEX-      |   | I    |
| 10                      | CTLR SIGNAL | User Controller Signal. Pass-through to Port 1 (P1) for customer use.                                   | I/O  |
| 11                      | +V HALL OUT | Low Power Supply For Hall Sensors (+6 V @ 30 mA). Referenced to signal ground. Short circuit protected. | O    |
| 12                      | GND         | Signal Ground   | SGND |
| 13                      | +5V @ 250mA | ±5 V @ 250 mA low power supply for customer use. Short circuit protected. Referenced to signal ground.  | O    |
| 14                      | TACH        | Negative Tachometer Input (Maximum ±60 V). Use signal ground for positive input.                        | I    |
| 15                      | CTLR POWER  | Controller Power. Pass-through to Port 1 (P1) for customer use.   | I/O  |

| P3 - Motor Power Connector |         |                     |     |
|----------------------------|---------|---------------------|-----|
| Pin                        | Name    | Description / Notes | I/O |
| 1                          | MOTOR A | Motor Phase A       | O   |
| 2                          | MOTOR B | Motor Phase B       | O   |
| 3                          | MOTOR C | Motor Phase C       | O   |

**P4 - AC Power Connector**

| Pin | Name     | Description / Notes                     | I/O |
|-----|----------|---|-----|
| 1   | AC1      | AC Supply Input (Single Or Three Phase) | I   |
| 2   | AC2      |   | I   |
| 3   | AC3      |   | I   |
| 4   | CASE GND | Case Ground                             | PE  |

## HARDWARE SETTINGS

### Switch Functions

| Switch | Description   | Setting                |                        |
|--------|---|------------------------|------------------------|
|        |   | On                     | Off                    |
| 1      | Test/Offset. Switches the function of the Test/Offset pot between an on-board command input for testing or a command offset adjustment. OFF by default.   | Test                   | Offset                 |
| 2      | Current loop proportional gain adjustment. ON by default.   | Decrease               | Increase               |
| 3      | Current scaling. When OFF, increases sensitivity of current sense thus reducing both peak and continuous current limit by 50%. The scaling of the current monitor output signal becomes ½ its ordinary value when this switch is OFF. | Full-current           | Half-current           |
| 4      | Outer loop integration. Activates or deactivates integration. ON, by default, for current mode and OFF for other modes.   | Inactive               | Active                 |
| 5      | Mode selection. See mode selection table below.   | -                      | -                      |
| 6      | Mode selection. See mode selection table below.   | -                      | -                      |
| 7      | Velocity feedback polarity. Changes the polarity of the internal feedback signal and the velocity monitor output signal. Inversion of the feedback polarity may be required to prevent a motor run-away condition.                    | Standard               | Inverted               |
| 8      | Current ratio. Used to set continuous-to-peak current ratio. Default is ON.   | Cont./Peak Ratio = 50% | Cont./Peak Ratio = 25% |
| 9      | Outer loop integral gain adjustment. It is recommended to leave this switch OFF for most applications, but ON for Hall Velocity Mode.   | Decrease               | Increase               |
| 10     | Hall sensor phasing. Selects 120°/60° commutation phasing. ON by default.   | 120°                   | 60°                    |

### Mode Selection Table

|                     | SW4 | SW5 | SW6 | Encoder       | Tachometer    |
|---------------------|-----|-----|-----|---------------|---------------|
| CURRENT             | ON  | OFF | OFF | Not Connected | Not Connected |
| DUTY CYCLE          | OFF | ON  | OFF | Not Connected | Not Connected |
| HALL VELOCITY*      | OFF | OFF | ON  | Not Connected | Not Connected |
| ENCODER VELOCITY*   | OFF | ON  | ON  | Connected     | Not Connected |
| TACHOMETER VELOCITY | OFF | OFF | OFF | Not Connected | Connected     |
| EXTERNAL VELOCITY   | OFF | OFF | OFF | Not Connected | Not Connected |

\*NOTE: See details of switch 7 for further Hall/Encoder Velocity configuration information.

### Potentiometer Functions

| Potentiometer | Description  | Turning CW                           |
|---------------|--|--------------------------------------|
| 1             | Loop gain adjustment for duty cycle / velocity modes. Turn this pot fully CCW in current mode.   | Increases gain                       |
| 2             | Current limit. It adjusts both continuous and peak current limit while maintaining their ratio.  | Increases limit                      |
| 3             | Reference gain. Adjusts the ratio between input signal and output variables (voltage, current, or velocity).   | Increases gain                       |
| 4             | Offset / Test. Used to adjust any imbalance in the input signal or in the amplifier. Can also be used as an on-board signal source for testing purposes. | Adjusts offset in negative direction |

Note: Potentiometers are approximately linear and have 12 active turns with 1 inactive turn on each end.

**Through-hole Components<sup>†</sup>**

| Location | Description  |
|----------|--|
| C67*     | Velocity Loop Integrator. Through-hole capacitor that can be added for more precise velocity loop tuning. See section below on Tuning with Through-hole components for more details.     |
| C69*     | Current Loop Integrator. Through-hole capacitor that can be added for more precise current loop tuning. See section below on Tuning with Through-hole components for more details.       |
| R26*     | Current Loop Proportional Gain. Through-hole resistor that can be added for more precise current loop tuning. See section below on Tuning with Through-hole components for more details. |

*Tuning With Through-hole Components*

In general, the drive will not need to be further tuned with through-hole components. However, for applications requiring more precise tuning than what is offered by the potentiometers and dipswitches, the drive can be manually modified with through-hole resistors and capacitors as denoted in the above table. By default, the through-hole locations are not populated when the drive is shipped. Before attempting to add through-hole components to the board, consult the section on loop tuning in the installation notes on the manufacturer's website. Some general rules of thumb to follow when adding through-hole components are:

- A larger resistor value will increase the proportional gain, and therefore create a faster response time.
- A larger capacitor value will increase the integration time, and therefore create a slower response time.

Proper tuning using the through-hole components will require careful observation of the loop response on a digital oscilloscope to find the optimal through-hole component values for the specific application.

**<sup>†</sup>Note: Damage done to the drive while performing these modifications will void the warranty.**

**MECHANICAL INFORMATION**

**P1 - Signal Connector**

|                       |                     |   |
|-----------------------|---------------------|---|
| Connector Information |                     | 25-pin, female D-sub  |
| Mating Connector      | Details             | TYCO: Plug P/N 5205208-1; Housing P/N 5745173-1; Terminals P/N 1658540-5 (loose) or 1658540-4 (strip) |
|                       | Included with Drive | No  |

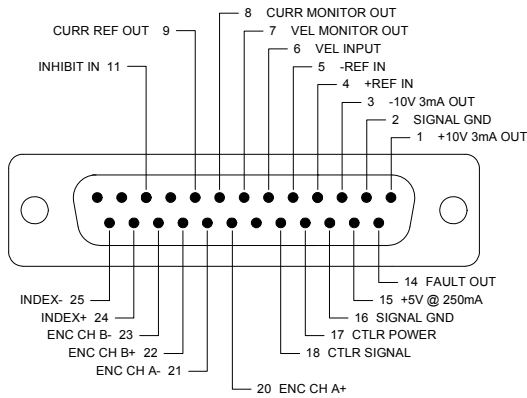

**P2 - Feedback Connector**

|                       |                     |  |
|-----------------------|---------------------|--|
| Connector Information |                     | 15-pin, female D-sub   |
| Mating Connector      | Details             | TYCO: Plug P/N 205206-3; Housing P/N 5745172-1; Terminals P/N 1658540-5 (loose) or 1658540-4 (strip) |
|                       | Included with Drive | No   |

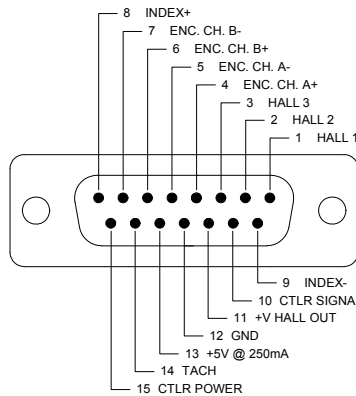



**P3 - Motor Power Connector**

|                       |                     |  |
|-----------------------|---------------------|--|
| Connector Information |                     | 3-contact, 11.10 mm spaced, tri-barrier terminal block |
| Mating Connector      | Details             | Not applicable   |
|                       | Included with Drive | Not applicable   |

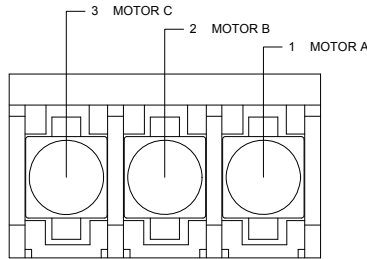

**P4 - AC Power Connector**

|                       |                     |  |
|-----------------------|---------------------|--|
| Connector Information |                     | 4-contact, 11.10 mm spaced, tri-barrier terminal block |
| Mating Connector      | Details             | Not applicable   |
|                       | Included with Drive | Not applicable   |

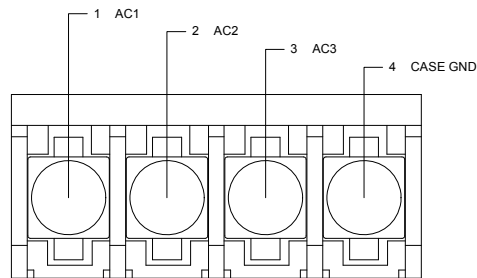

**MOUNTING DIMENSIONS**

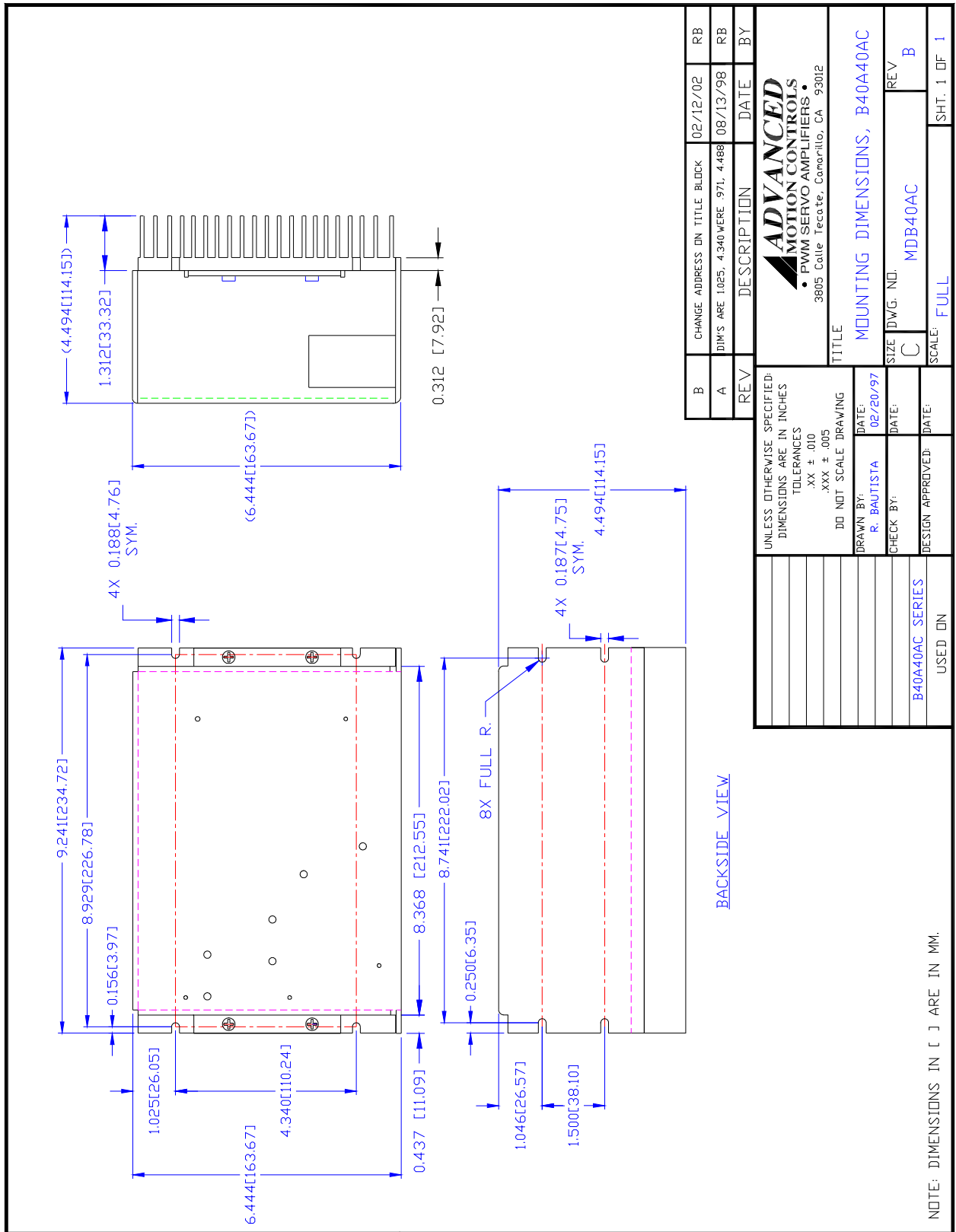

|  |  |          |      |
|--|--|----------|------|
| B  | CHANGE ADDRESS ON TITLE BLOCK          | 02/12/02 | RB   |
| A  | DIMS ARE 1.025, 4.340 WERE .971, 4.488 | 08/13/98 | RB   |
| REV  | DESCRIPTION                            | DATE     | BY   |
|  |  |          |      |
| <p><b>ADVANCED MOTION CONTROLS</b><br/>• PWM SERVO AMPLIFIERS •<br/>3805 Calle Tecate, Camarillo, CA 93012</p> |  |          |      |
| TITLE  |  |          |      |
| MOUNTING DIMENSIONS, B40A40AC  |  |          |      |
| SIZE   | DWG. NO.                               | REV      |      |
| C  | MDB40AC                                | B        |      |
| SCALE:   | FULL                                   | SHT. 1   | OF 1 |

UNLESS OTHERWISE SPECIFIED:  
DIMENSIONS ARE IN INCHES  
TOLERANCES  
XX ± .010  
.XXX ± .005  
DO NOT SCALE DRAWING

DESIGNED BY: \_\_\_\_\_ DATE: \_\_\_\_\_  
DRAWN BY: R. BAUTISTA DATE: 02/20/97  
CHECK BY: \_\_\_\_\_ DATE: \_\_\_\_\_  
DESIGN APPROVED: \_\_\_\_\_ DATE: \_\_\_\_\_

B40A40AC SERIES  
USED IN

**PART NUMBERING INFORMATION**

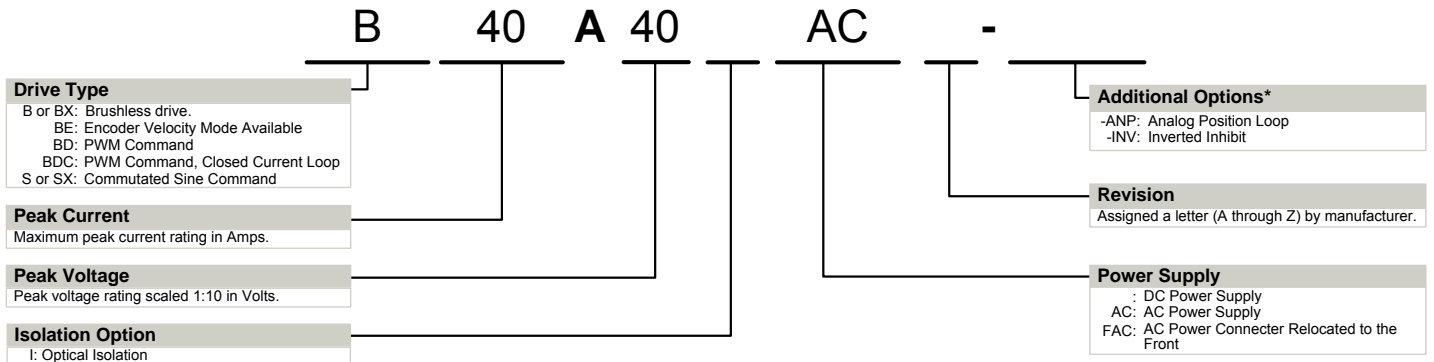

\* Options available for orders with sufficient volume. Contact *ADVANCED* Motion Controls for more information.  
 \*\* Isolation comes standard on all AC supply drives and most DC supply drives 200V and above. Consult selection tables of the website or drive datasheet block diagram to see if isolation is included.

*ADVANCED* Motion Controls analog series of servo drives are available in many configurations. Note that not all possible part number combinations are offered as standard drives. All models listed in the selection tables of the website are readily available, standard product offerings.

*ADVANCED* Motion Controls also has the capability to promptly develop and deliver specified products for OEMs with volume requests. Our Applications and Engineering Departments will work closely with your design team through all stages of development in order to provide the best servo drive solution for your system. Equipped with on-site manufacturing for quick-turn customs capabilities, *ADVANCED* Motion Controls utilizes our years of engineering and manufacturing expertise to decrease your costs and time-to-market while increasing system quality and reliability.

**Examples of Modifications and Customized Products**

- |   |  |
|---|--|
| <ul style="list-style-type: none"> <li>▲ Integration of Drive into Motor Housing</li> <li>▲ Mount OEM PCB onto Drive Without Cables</li> <li>▲ Multi-axis Configuration for Compact System</li> <li>▲ Custom PCB and Baseplate for Optimized Footprint</li> <li>▲ RTV/Epoxy Components for High Vibration</li> <li>▲ OEM Specified Connectors for Instant Compatibility</li> <li>▲ OEM Specified Silkscreen for Custom Appearance</li> <li>▲ Increased Thermal Limits for High Temp. Operation</li> </ul> | <ul style="list-style-type: none"> <li>▲ Integrate OEM Circuitry onto Drive PCB</li> <li>▲ Custom Control Loop Tuned to Motor Characteristics</li> <li>▲ Custom I/O Interface for System Compatibility</li> <li>▲ Preset Switches and Pots to Reduce User Setup</li> <li>▲ Optimized Switching Frequency</li> <li>▲ Ramped Velocity Command for Smooth Acceleration</li> <li>▲ Remove Unused Features to Reduce OEM Cost</li> <li>▲ Application Specific Current and Voltage Limits</li> </ul> |
|---|--|

Feel free to contact Applications Engineering for further information and details.

**Available Accessories**

*ADVANCED* Motion Controls offers a variety of accessories designed to facilitate drive integration into a servo system. Visit [www.a-m-c.com](http://www.a-m-c.com) to see which accessories will assist with your application design and implementation.



All specifications in this document are subject to change without written notice. Actual product may differ from pictures provided in this document.