

7/14/98

Sold By: Servo Systems Co. • 53 Green Pond Road, Suite #2 • Rockaway, NJ 07866
(973) 335-1007 • Toll Free: (800) 922-1103 • Fax: (973) 335-1661 • www.servosystems.com

User's Manual

3540 M

Step Motor Driver

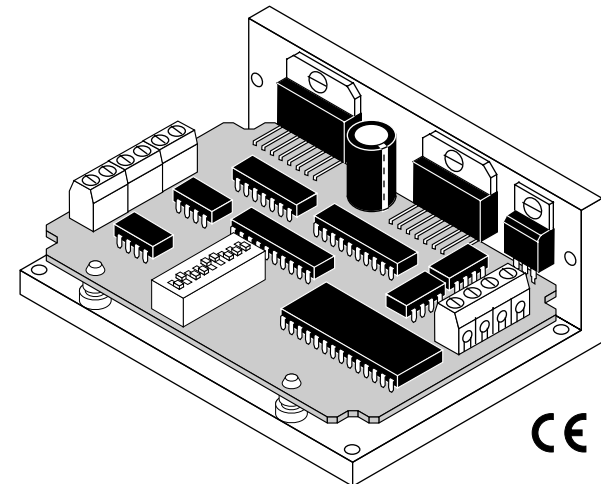

Applied Motion Products, Inc.
404 Westridge Drive • Watsonville, CA 95076
Tel (831) 761-6555 (800) 525-1609 Fax (831) 761-6544

 **Applied
Motion
Products**
motors • drives • controls

Introduction

Thank you for selecting an Applied Motion Products motor control. We hope our dedication to performance, quality and economy will make your motion control project successful.

If there's anything we can do to improve our products or help you use them better, please call or fax. We'd like to hear from you. Our phone number is (800) 525-1609 or you can reach us by fax at (831) 761-6544.

Features

- Drives sizes 14 through 34 step motors
- Pulse width modulation, MOSFET 3 state switching amplifiers
- Phase current from 0.4 to 3.5 amps (switch selectable, 32 settings)
- Optically isolated step, direction and enable inputs
- Half, 1/5, 1/10, 1/64 step (switch selectable)
- Automatic 50% idle current reduction (can be switched off)

Block Diagram

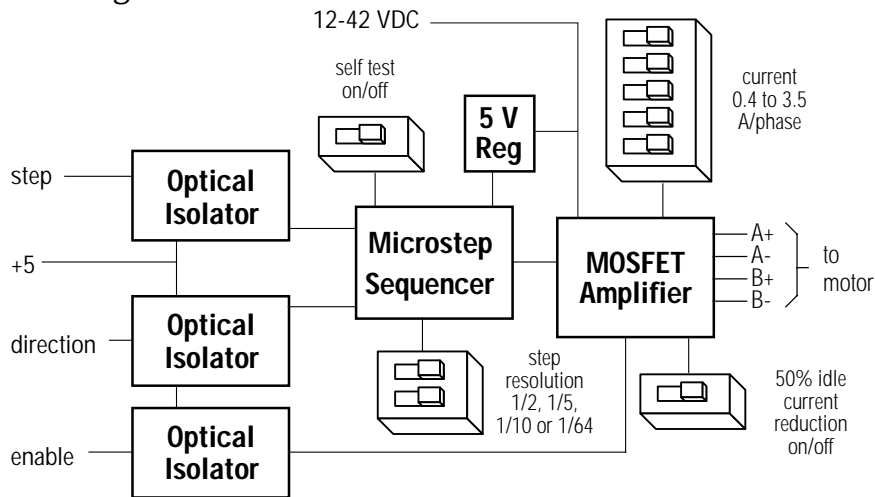

Technical Specifications

Amplifiers Dual, bipolar MOSFET H-bridge, pulse width modulated three state switching at 20kHz. 12-42 VDC input. 0.4 - 3.5 amps/phase output current, switch selectable in 0.1 A increments. 122 watts maximum output power. Automatic idle current reduction (switch selectable), reduces current to 50% of setting after one second.

Inputs Step, direction and enable, optically isolated, 5V logic. 5mA/signal, sink requirement. Motor steps on rising edge of step input. 0.5 μ sec minimum pulse width. 2 μ sec minimum set up time for direction signal.

Physical Mounted on 1/4 inch thick black anodized aluminum heat transfer chassis. 1.5 x 3.0 x 4.0 inches overall. Power on red LED. See drawing on page 14 for more information. Maximum chassis temperature: 70° C.

Connectors European style screw terminal blocks. Max wire size: AWG 18. Motor: 4 position (A+, A-, B+, B-) Signal Input: 4 position (+5, STEP, DIR, EN) DC Input: 2 position (V+, V-)

Self Test Switch selectable, rotates motor 1/2 revolution each direction at 100 steps/second, half step mode.

Microstepping Four switch selectable step resolutions. With 1.8 μ motor:
 Half step (400 steps/rev)
 1/5 step (1000 s/r)
 1/10 step (2000 s/r)
 1/64 step (12,800 s/r)
 Other resolutions, up to 12,800, available to qualified OEMs upon request.

CE Mark Complies with EN55011A and EN50082-1(1992).



Mechanical Outline

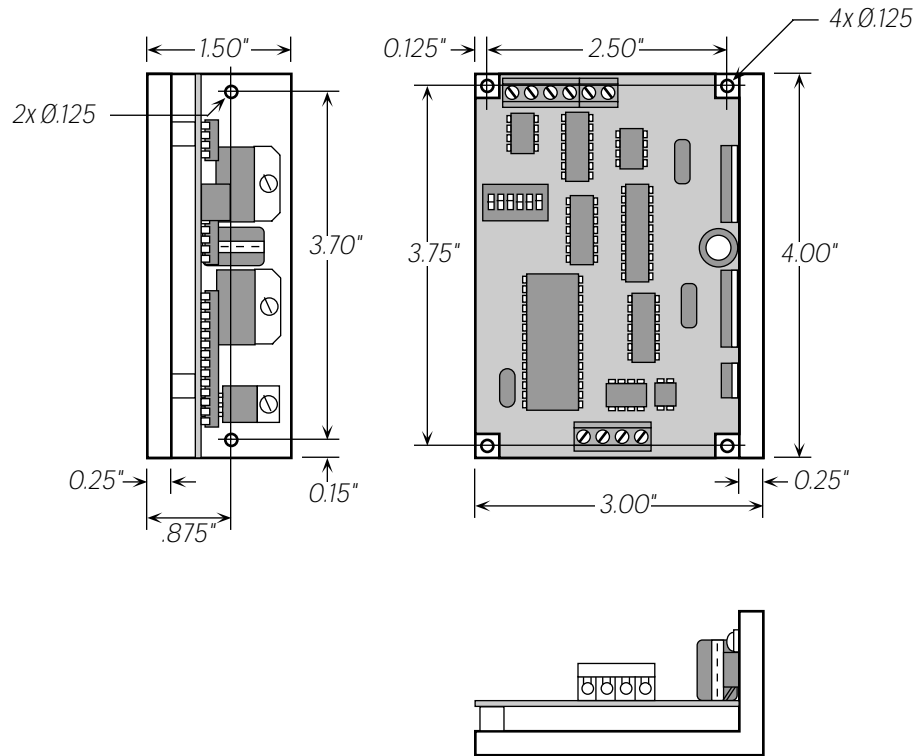

Getting Started

To use your Applied Motion Products motor control, you will need the following:

- a 12-42 volt DC power supply for the motor. Please read the section entitled *Choosing a Power Supply* for help in choosing the right power supply.
- +5 volts DC, 15mA to activate the optoisolation circuits (if you don't use 5 volt logic, see page 6.) This is provided by most indexers and PLCs.
- a source of step pulses capable of sinking at least 5 mA
- if your application calls for bidirectional rotation, you'll also need a direction signal, capable of sinking 5 mA
- a compatible step motor
- a small flat blade screwdriver for tightening the connectors

The sketch below shows where to find the important connection and adjustment points. Please examine it now.

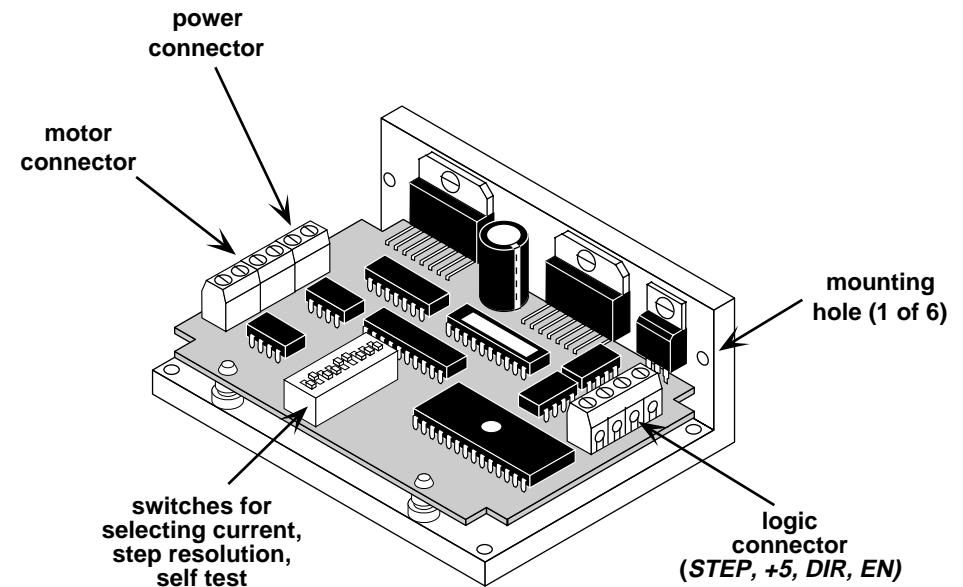

Connecting the Power Supply

If you need information about choosing a power supply, please read *Choosing a Power Supply* located on page 12 of this manual. The PS430 from Applied Motion Products is a good supply for this drive.

If your power supply does not have a fuse on the output or some kind of short circuit current limiting feature you need to put a 4 amp fast acting fuse between the drive and power supply. Install the fuse on the + power supply lead.

Connect the motor power supply + terminal to the driver terminal labeled "+ VDC". Connect power supply D to the drive terminal labeled "VDC D ". Use no smaller than 20 gauge wire. **Be careful not to reverse the wires.** Reverse connection will destroy your driver, void your warranty and generally wreck your day.

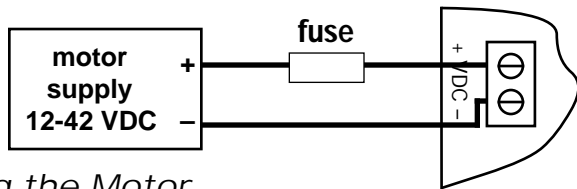

Connecting the Motor

Warning: When connecting the motor to the driver, be sure that the motor power supply is off. Secure any unused motor leads so that they can't short out to anything. Never disconnect the motor while the drive is powered up. Never connect motor leads to ground or to a power supply!

You must now decide how to connect your motor to the drive.

Four lead motors can only be connected one way. Please follow the sketch at the right.

Six lead motors can be connected in series or center tap. In series mode, motors produce more torque at low speeds, but cannot run as fast as in the center tap configuration. In series operation, the motor should be operated at 30% less than rated current to prevent overheating. Wiring diagrams for both connection methods are shown on the next page. NC means not connected to anything.

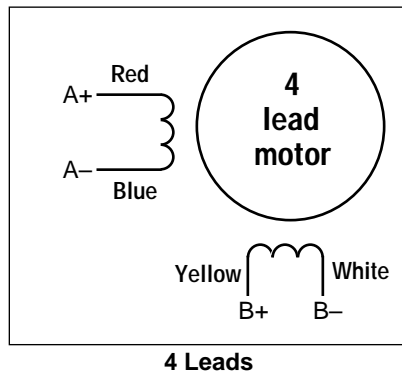

Mounting the Drive

You can mount your drive on the wide or the narrow side of the chassis. If you mount the drive on the wide side, use #4 screws through the four corner holes. For narrow side mounting applications, you can use #4 screws in the two side holes.

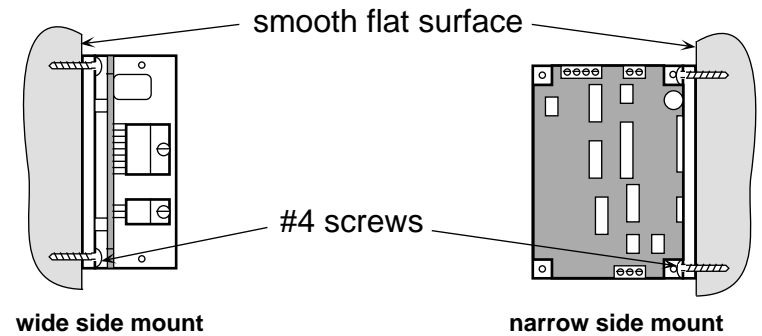

The amplifiers in the drive generate heat. Unless you are running at 1 amp or below, you may need a heat sink. To operate the drive continuously at maximum power you must properly mount it on a heat sinking surface with a thermal constant of no more than 4°C/watt. Applied Motion Products can provide a compatible heat sink. Often, the metal enclosure of your system will make an effective heat sink.

Never use your drive in a space where there is no air flow or where other devices cause the surrounding air to be more than 70 °C. Never put the drive where it can get wet or where metal particles can get on it.

Choosing a Power Supply

Voltage

Chopper drives work by switching the voltage to the motor terminals on and off while monitoring current to achieve a precise level of phase current. To do this efficiently and silently, you'll want to have a power supply with a voltage rating at least five times that of the motor. Depending on how fast you want to run the motor, you may need even more voltage. More is better, the only upper limit being the maximum voltage rating of the drive itself: 42 volts (including ripple).

If you choose an unregulated power supply, do not exceed 30 volts DC. This is because unregulated supplies are rated at full load current. At lesser loads, like when the motor is not moving, the actual voltage can be up to 1.4 times the voltage list on the power supply label.

Current

The maximum supply current you will need is the sum of the two phase currents. However, you will generally need a lot less than that, depending on the motor type, voltage, speed and load conditions. That's because the 3540 M uses switching amplifiers, converting a high voltage and low current into lower voltage and higher current. The more the power supply voltage exceeds the motor voltage, the less current you'll need from the power supply.

We recommend the following selection procedure:

1. If you plan to use only a few drives, get a power supply with at least twice the rated phase current of the motor.
2. If you are designing for mass production and must minimize cost, get one power supply with more than twice the rated current of the motor. Install the motor in the application and monitor the current coming out of the power supply and into the drive at various motor loads. This will tell you how much current you really need so you can design in a lower cost power supply.

If you plan to use a regulated power supply you may encounter a problem with current foldback. When you first power up your drive, the full current of both motor phases will be drawn for a few milliseconds while the stator field is being established. After that the amplifiers start chopping and much less current is drawn from the power supply. If your power supply thinks this initial surge is a short circuit it may "foldback" to a lower voltage. With many foldback schemes the voltage returns to normal only after the first motor step and is fine thereafter. In that sense, unregulated power supplies are better. They are also less expensive.

The PS430 from Applied Motion Products is a good supply to use with the 3540 M.

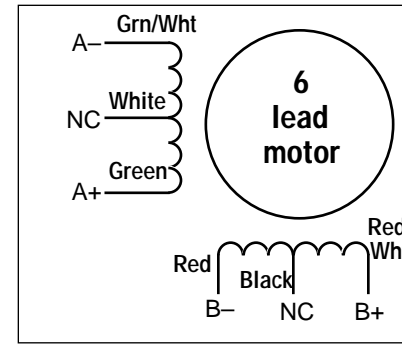

6 Leads Series Connected

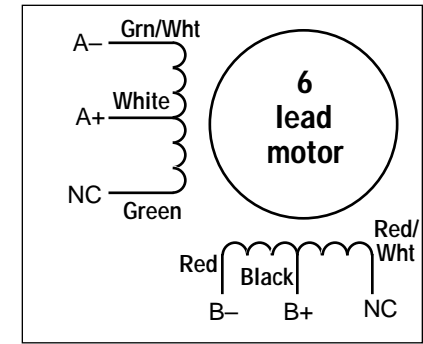

6 Leads Center Tap Connected

Eight lead motors can also be connected in two ways: series or parallel. As with six lead motors, series operation gives you more torque at low speeds and less torque at high speeds. In series operation, the motor should be operated at 30% less than the rated current to prevent over heating. The wiring diagrams for eight lead motors are shown below.

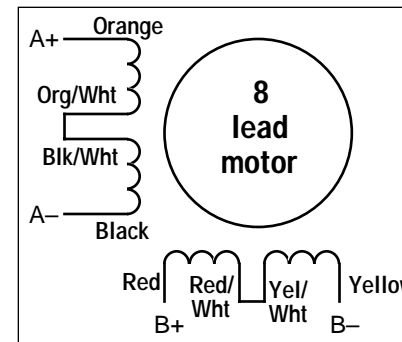

8 Leads Series Connected

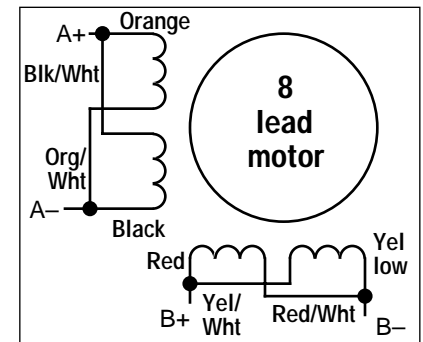

8 Leads Parallel Connected

Connecting Logic

The 3540 M contains optical isolation circuitry to prevent the electrical noise inherent in switching amplifiers from interfering with your circuits. Optical isolation is accomplished by powering the motor driver from a different supply than your circuits. There is no electrical connection between the two: signal communication is achieved by infrared light. When your circuit is in the logic low state (near 0 volts), it is directing electrical current through an LED that is built into the drive. The LED, in turn, produces infrared light which turns on a phototransistor that is wired to the brains of the drive. When your circuit is in the logic high state, the LED and phototransistor turn off.

A schematic diagram of the input circuit is shown below.

You must supply 5 volts DC to supply current to the LEDs on the input side of the optoisolators. The maximum current draw is 15 mA total.

Your controlling logic must be capable of sinking at least 5 mA to control each drive input. Most CMOS and open collector TTL devices are directly compatible with this drive. Logic low, or 0, for a given input occurs when that input is pulled to less than 0.8 volts DC. In this state the LED is conducting current. Logic high, or 1, occurs when the input is greater than 4 volts or open.

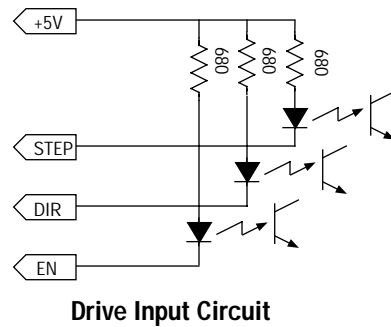

Drive Input Circuit

STEP tells the driver when to move the motor one step. The drive steps on the falling edge of the pulse. The minimum pulse width is 0.5 microseconds.

DIRECTION signals which way the motor should turn. See the step table on page 8 for details. The *DIRECTION* signal should be changed at least 2 microseconds before a step pulse is sent. **If you change the state of the direction input and send a step pulse at the same instant the motor may take a step in the wrong direction.**

ENABLE allows the user to turn off the current to the motor by setting this signal to logic 0. The logic circuitry continues to operate, so the drive "remembers" the step position even when the amplifiers are disabled. However, the motor may move slightly when the current is removed depending on the exact motor and load characteristics. **If you have no need to disable the amplifiers, you don't need to connect anything to the ENABLE input.**

Using Logic Voltages other than 5 volts DC

The 3540 M was designed to be used with 5 volt CMOS and TTL logic signals. To prevent interference between the drive and the controlling logic, the input signals are optically isolated. That means that your signals are powering LEDs within the drive's optocoupler circuits. The LEDs require at least 5 milliamps of current to turn on, but cannot stand more than 20 mA. Since the LEDs themselves only drop about two volts, current limiting resistors must be used on each logic input.

Idle Current Reduction

Your drive is equipped with a feature that automatically reduces the motor current by 50% anytime the motor is not moving. This reduces drive heating by about 50% and lowers motor heating by 75%. This feature can be disabled if desired so that full current is maintained at all times. This is useful when a high holding torque is required. To minimize motor and drive heating we highly recommend that you enable the idle current reduction feature unless your application strictly forbids it.

Idle current reduction is enabled by sliding switch #4 toward the *50% IDLE* label, as shown in the sketch below. Sliding the switch away from the *50% IDLE* label disables the reduction feature.



Idle Current Reduction Selected

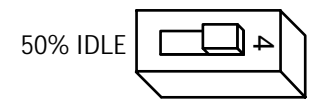

No Current Reduction

Self Test

The 3540 M includes a self test feature. This is used for trouble shooting. If you are unsure about the motor or signal connections to the drive, or if the 3540 M isn't responding to your step pulses, you can turn on the self test.

To activate the self test, slide switch #1 toward the *TEST* label. The drive will slowly rotate the motor, 1/2 revolution forward, then 1/2 rev backward. The pattern repeats until you slide the switch away from the *TEST* label. The 3540 M always uses half step mode during the self test, no matter how you set switches 2 and 3. The self test ignores the *STEP* and *DIRECTION* inputs while operating. The *ENABLE* input continues to function normally.

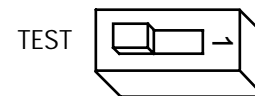

Self Test ON

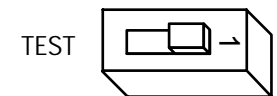

Self Test OFF

Microstepping

Most step motor drives offer a choice between full step and half step resolutions. In most full step drives, both motor phases are used all the time. Half stepping divides each step into two smaller steps by alternating between both phases on and one phase on. Microstepping drives like the 3540 M precisely control the amount of current in each phase at each step position as a means of electronically subdividing the steps even further. The 3540 M offers a choice of half step and 3 microstep resolutions. The highest setting divides each full step into 64 microsteps, providing 12,800 steps per revolution when using a 1.8° motor.

In addition to providing precise positioning and smooth motion, microstep drives can be used to provide motion in convenient units. When the drive is set to 2000 steps/rev (1/10 step) and used with a 5 pitch lead screw, you get .0001 inches/step.

Setting the step resolution is easy. Look at the dip switch on the 3540 M. Next to switches 2 and 3, there are labels on the printed circuit board. Each switch has two markings on each end. Switch 2 is marked 1/5, 1/10 at one end and 1/5, 1/64 at the other. Switch 3 is labeled 1/2, 1/5 and 1/10, 1/64. To set the drive for a resolution, push both switches toward the proper label. For example, if you want 1/10 step, push switch 2 toward the 1/10 label (to the left) and push switch 3 toward 1/10 (on the right).

Please refer to the table below and set the switches for the resolution you want.

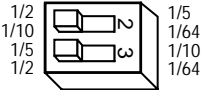
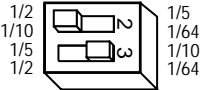
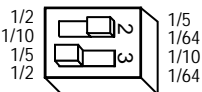
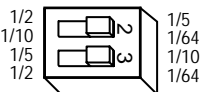
<p>400 STEPS/REV (HALF)</p> 	<p>2000 STEPS/REV (1/10)</p> 
<p>1000 STEPS/REV (1/5)</p> 	<p>12800 STEPS/REV (1/64)</p> 

We have included the proper resistor (680 ohms) within the drive for 5 volt operation. Therefore, if your logic voltage is 5 volts, you do not need to add resistors externally.

If your logic voltage is higher than five volts, you must add a resistor in series with each signal that you use (STEP, DIR and EN). The recommended wiring diagram is shown below. Table I lists the appropriate resistor value to use for a given power supply voltage. 1/4 watt or larger resistors should be used.

Please take care not to reverse the wiring, as damage to the LEDs will result rendering the drives inoperable. Check your wiring carefully before turning on the power supply!

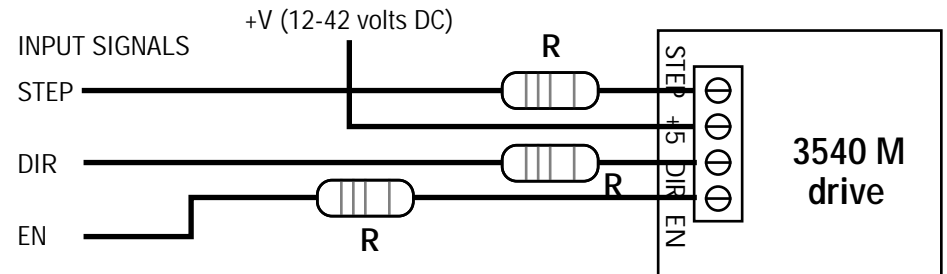

Note: DIR signal is only required for bidirectional motion.
EN signal is only required to shut off motor current.
Both inputs can be left open if not needed.

Supply Voltage	R Ohms	Supply Voltage	R Ohms	Supply Voltage	R Ohms
12	1200	21	3000	30	4700
15	1800	24	3600	33	5100
18	2400	27	4200	35	5600

**Step Table
(half stepping)**

Step	A+	A-	B+	B-
0	open	open	+	-
1	+	-	+	-
2	+	-	open	open
3	+	-	-	+
4	open	open	-	+
5	-	+	-	+
6	-	+	open	open
7	-	+	+	-
8	open	open	+	-

Step 0 is the Power Up State

Setting Phase Current

Before you turn on the power supply the first time, you need to set the driver for the proper motor phase current. The rated current is usually printed on the motor label. The 3540 M drive current is easy to set. If you wish, you can learn a simple formula for setting current and never need the manual again. Or you can skip to the table on the next page, find the current setting you want, and set the DIP switches according to the picture.

Current Setting Formula

Locate the bank of tiny switches near the motor connector. Four of the switches have a value of current printed next to them, such as 0.4 and 0.8. Each switch controls the amount of current, in amperes (A), that its label indicates. There is always a base of current of 0.4 A. To add to that, slide the appropriate switches toward their labels on the PC board. You may need your small screwdriver for this.

Example

Suppose you want to set the driver for 2.2 amps per phase. You need the 0.4 A base current plus another 1.6 and 0.2 A.

$$2.2 = 0.4 + 1.6 + 0.2$$

Slide the 1.6 and 0.2 A switches toward the labels as shown in the figure.

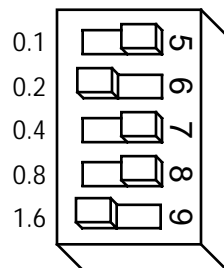

Current Setting Table

0.4 AMPS/ PHASE	1.2 AMPS/ PHASE	2.0 AMPS/ PHASE	2.8 AMPS/ PHASE
0.5 AMPS/ PHASE	1.3 AMPS/ PHASE	2.1 AMPS/ PHASE	2.9 AMPS/ PHASE
0.6 AMPS/ PHASE	1.4 AMPS/ PHASE	2.2 AMPS/ PHASE	3.0 AMPS/ PHASE
0.7 AMPS/ PHASE	1.5 AMPS/ PHASE	2.3 AMPS/ PHASE	3.1 AMPS/ PHASE
0.8 AMPS/ PHASE	1.6 AMPS/ PHASE	2.4 AMPS/ PHASE	3.2 AMPS/ PHASE
0.9 AMPS/ PHASE	1.7 AMPS/ PHASE	2.5 AMPS/ PHASE	3.3 AMPS/ PHASE
1.0 AMPS/ PHASE	1.8 AMPS/ PHASE	2.6 AMPS/ PHASE	3.4 AMPS/ PHASE
1.1 AMPS/ PHASE	1.9 AMPS/ PHASE	2.7 AMPS/ PHASE	3.5 AMPS/ PHASE