

REV.	DESCRIPTION	ZONE	ECO	DATE	APPROVED
1	WORK IN PROGRESS			2/19/2008	M. TRAN
2	PULLEY HOUSING WIDTH CHANGED TO 125mm, REDUCTION OF 11mm.	E2, F2		2/22/2008	M. TRAN
3	PREP FOR WEB RELEASE		N/A	10/6/10	GS

NOTES:
1. ENTER NOTES

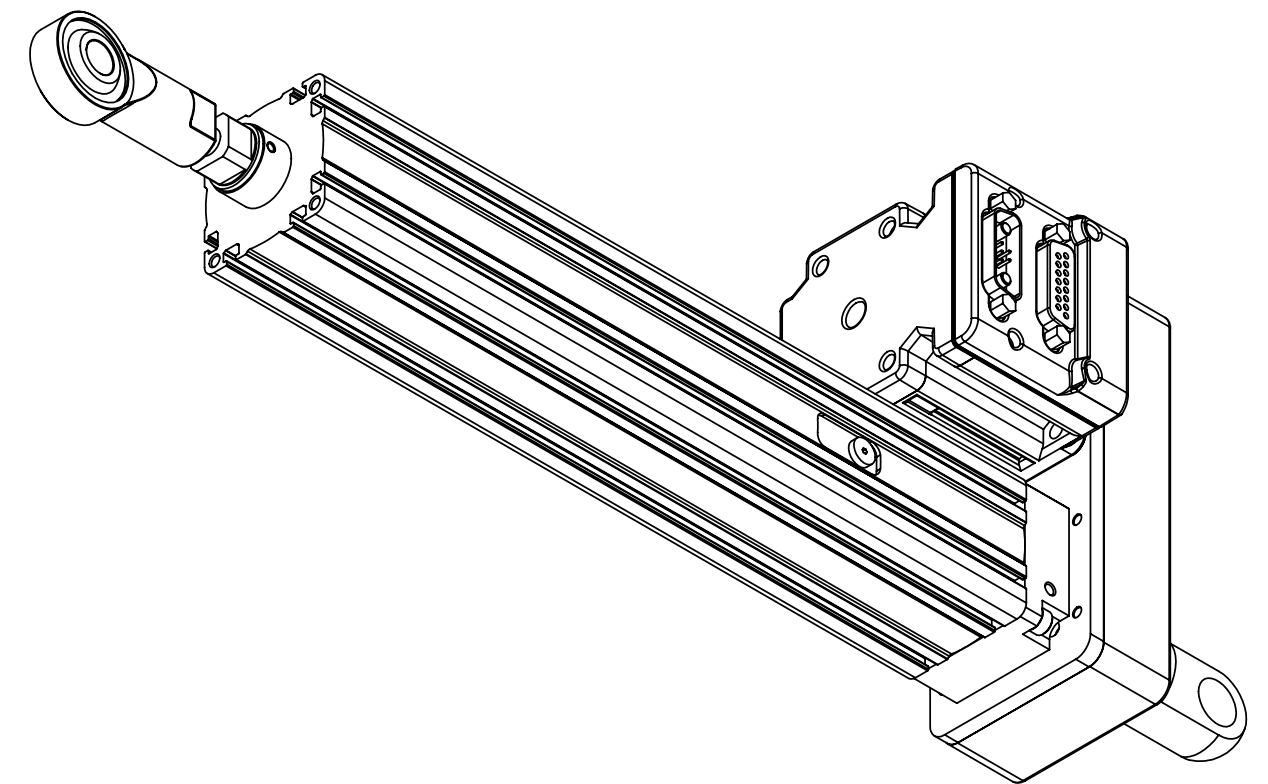
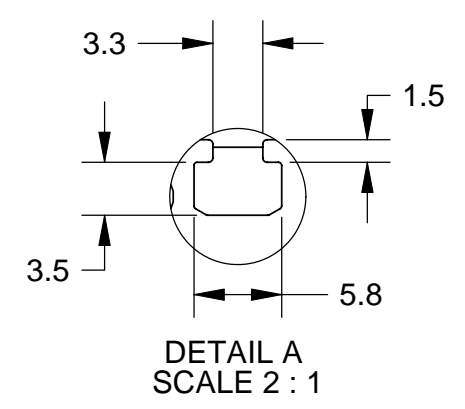
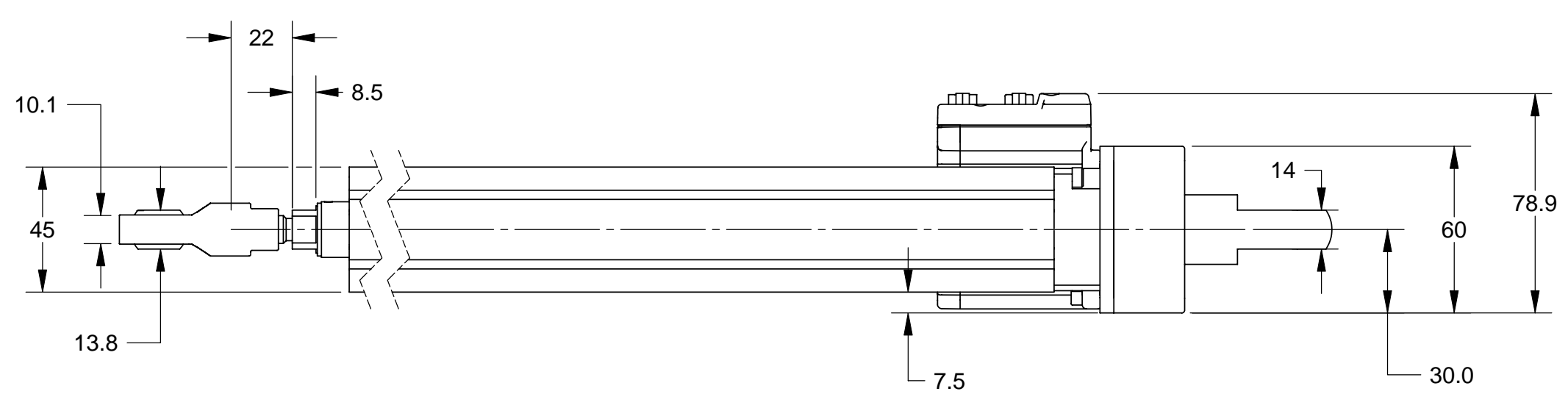
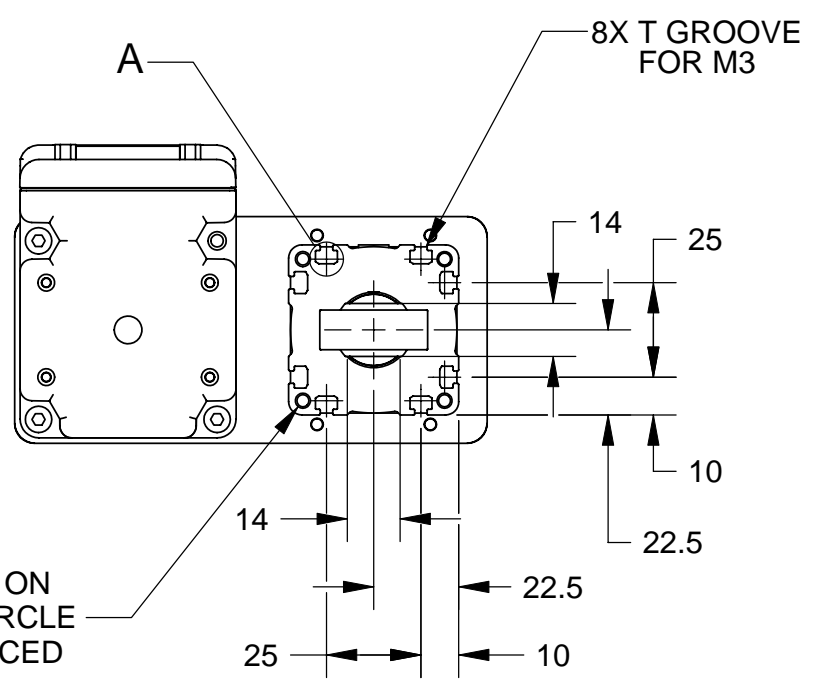
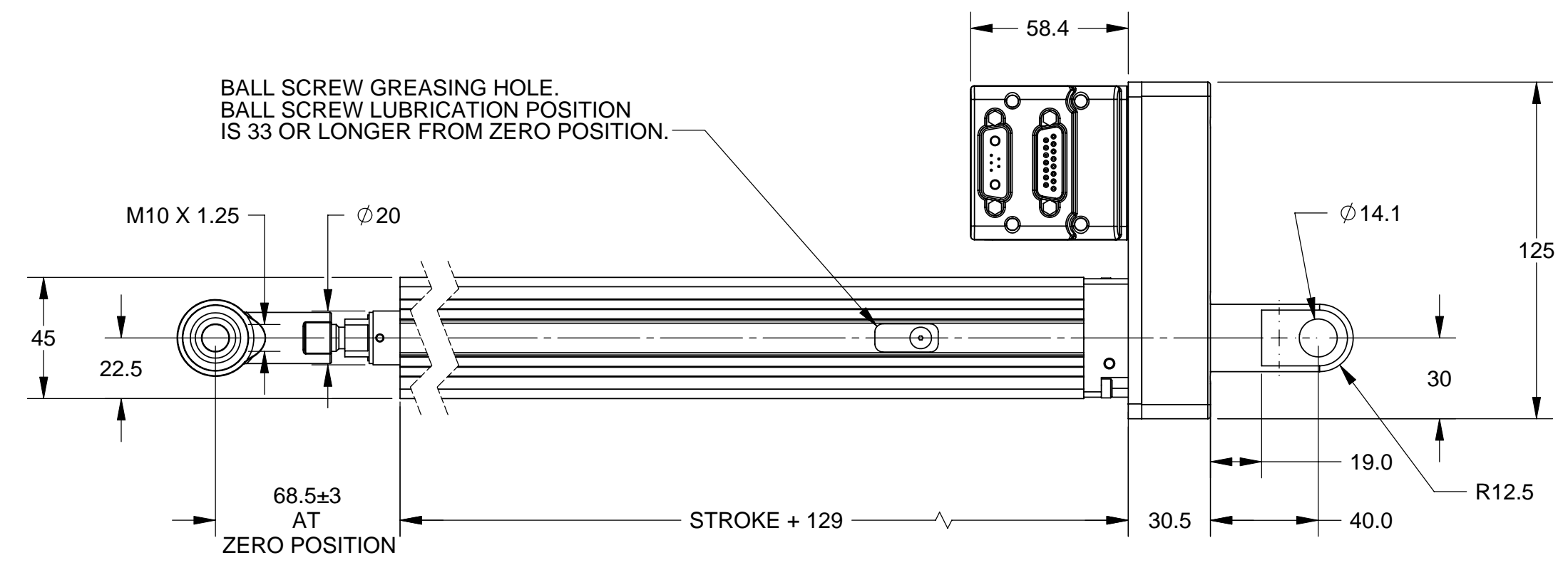

THIS DOCUMENT AND ENTIRE INFORMATION HERON ARE PROPRIETARY TO OEM DYNAMICS AND SHALL NOT BE USED IN ANY WAY DETRIMENTAL TO OEM DYNAMICS INTEREST NOR REPRODUCED WHATSOEVER WITHOUT EXPRESS CONSENT				California, USA www.OEMDynamics.com	
MATERIAL	FINISH	DRAWN	DATE	TITLE	
/	/	M. TRAN	2/19/2008	SPECIFICATION DRAWING	
		ENGR	DATE	SIZE	REV
		M. TRAN	2/19/2008	C	3
METRIC THIRD ANGLE PROJECTION		UNLESS OTHERWISE SPECIFIED: DIMENSIONS ARE MILLIMETERS AND TOLERANCES ARE: DECIMALS: .XX ± NA ANGLES: .XX ± NA ° .X ± NA .X ± NA °		DWG NO VLCT45-XXXX-XXXX-XXX-XXXXX4X	
		INTERPRET DIMENSIONS AND TOLERANCES PER ASME Y14.5M - 1994.		DO NOT SCALE DRAWING SCALE 1:2 SHEET 1 OF 1	