

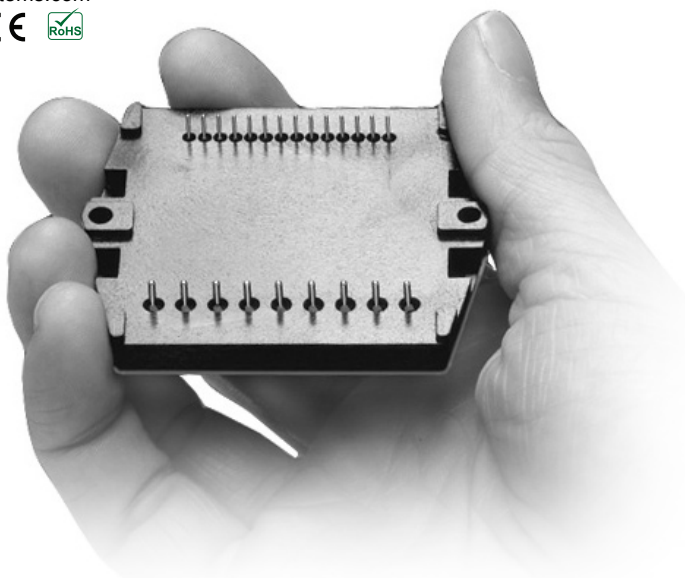

IM483H Plus IM805H Plus

**HIGH PERFORMANCE
ULTRA-MINIATURE MICROSTEPPING
HYBRID DRIVERS**



FEATURES

- Very Low Cost
- Ultra Miniature Size
(2.10 x 2.6 x 0.362 inches)
(53.34 x 66.04 x 9.19 mm)
- Advanced Hybrid Design
- High Input Voltage
IM483H PLUS: +12 to +48VDC
IM805H PLUS: +12 to +75VDC
- High Output Current
IM483H PLUS: 3A RMS, 4A Peak
IM805H PLUS: 5A RMS, 7A Peak
- Up to 2.5MHz Step Clock Rate
- No Minimum Inductance
- FAULT Input and Output
- Short Circuit and Over Temperature Protection
- Microstep Resolution to 51,200 Step/Rev (1.8° Motor)
- Microstep Resolutions can be Changed "On-The-Fly" Without Loss of Motor Position
- Variable 20-60 kHz Chopping Rate
- 16 Selectable Resolutions Both in Decimal and Binary
- Adjustable Automatic Current Reduction
- At Full Step Output
- Optional Cooling Fan (HFC-22)
- Optional Receptacle Carrier (PR-22)

DESCRIPTION

The IM483H PLUS and IM805H PLUS are high performance, low-cost microstepping drivers that utilize advanced hybrid technology to greatly reduce size without sacrificing fea-

*OPTION:
Hybrid Driver
Mounted with
HFC-22
Heat Sink/
Fan/Clip
Assembly.*

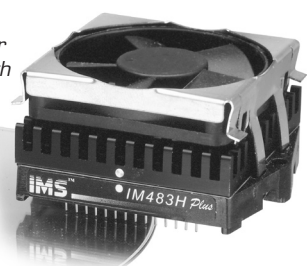

tures. Both are exceptionally small, easy to interface and use, and yet powerful enough to handle the most demanding applications.

The IM483H PLUS and IM805H PLUS have 16 built-in microstep resolutions (both binary and decimal). The resolution can be changed at any time without the need to reset the driver. This feature allows the user to rapidly move long distances, yet precisely position the motor at the end of travel without the expense of high-performance controllers. In many instances mechanical gearing can be replaced with microstepping. This reduces cost and system size, and eliminates potential maintenance while increasing accuracy and smoothness.

With the development of proprietary and patented circuits, ripple current has been minimized to reduce the motor heating that is common with other designs. This feature allows the use of low inductance motors to improve high-speed performance and system efficiency.

The IM483H/IM805H PLUS microstepping hybrids are designed to be soldered directly into a PC board. This eliminates the need for wiring and mounting, thus saving design and assembly time, reducing system cost and increasing reliability.

The ultra-small size reduces the

overall space required in your system. In addition, each unit is 100% tested and comes with a 2-year warranty.

Available as options for the IM483H/IM805H PLUS are the HFC-22 Heat Sink/Fan/Clip assembly and the PR-22 Pin Receptacles with throwaway carrier. The HFC-22 provides a unique cooling solution and was designed specifically for the IM483H PLUS and IM805H PLUS Microstepping Hybrid Drivers. The HFC-22 will easily maintain a reliable rear plate temperature without using large heat sinks and cumbersome mounting hardware. The heat sink and fan are easily mounted to the driver by means of a removable clip developed by IMS, and when fully assembled with the IM483H PLUS or IM805H PLUS takes up only 6.8 cubic inches of space!

For applications where ease of removal is required, the PR-22 provides a reliable, high quality receptacle which comes attached to a high temperature plastic throwaway carrier that facilitates wave soldering.

These drives, because of their ultra-small size, advanced technology and low-cost, provide designers with affordable state-of-the-art solutions for the competitive edge needed in today's market.

ELECTRICAL SPECIFICATIONS

IM483H PLUS / IM805H PLUS

Input Voltage (Motor)*	+12 to +48 VDC / +12 to +75 VDC
Input Voltage (Logic).....	+5 VDC
Output Current Per Phase.....	0.4 to 4 Amps Peak (Max 3 Amps RMS) / 1 to 7 Amps Peak (Max 5 Amps RMS)
Step Clock Frequency (Max).....	2.5 MHz
Steps per Revolution – 1.8° Motor	200, 400, 800, 1000, 1600, 2000, 3200, 5000, 6400, 10000, 12800, 25000, 25600, 36000, 50000, 51200
Protection.....	Thermal, Phase to Phase, +V to Phase

*Includes motor back EMF, Power Supply Ripple and High Line.

PIN ASSIGNMENTS

CONNECTOR P1: 14 PIN		CONNECTOR P2: 9 PIN	
PIN	FUNCTION	PIN	FUNCTION
1	Current Reference	1	Phase B
2	Current Adjustment	2	Ground B
3	Current Reduction	3	Phase /B
4	Fault Input	4	Ground
5-8	Resolution Select 0-3	5	+V
9	Step Clock	6	+5V Input
10	Direction	7	Phase A
11	Enable	8	Ground A
12	On Full Step	9	Phase /A
13	Fault Output		
14	Reset		

TEMPERATURE

Storage	-40 to +125° C
Rear Mounting Surface (Max).....	0 to +85° C

ORDER INFORMATION

Name	Part Number
48V, 3A Microstepping Driver	XIM483H
75V, 5A Microstepping Driver	XIM805H
Isolating Thermal Pad (Included with Driver)	TI-22
Heat Sink/Fan/Clip Assembly	HFC-22
Driver Interface Board	INT-483H/INT-805H
Developer's Kit (Includes Driver, Interface Board, Heat Sink/Fan/Clip Assembly)	XIM483H-DK1/ XIM805H-DK1
23 Pin Receptacles with Throwaway Carrier	PR-22
Small Pry Bar (To Remove Throwaway Carrier and Driver from Pin Receptacles).....	PB-22
Analog Speed Control Board for XIM805H.....	OSC-805H
Mounting L-Bracket.....	MB-22

MECHANICAL SPECIFICATIONS

Dimensions in Inches (mm)

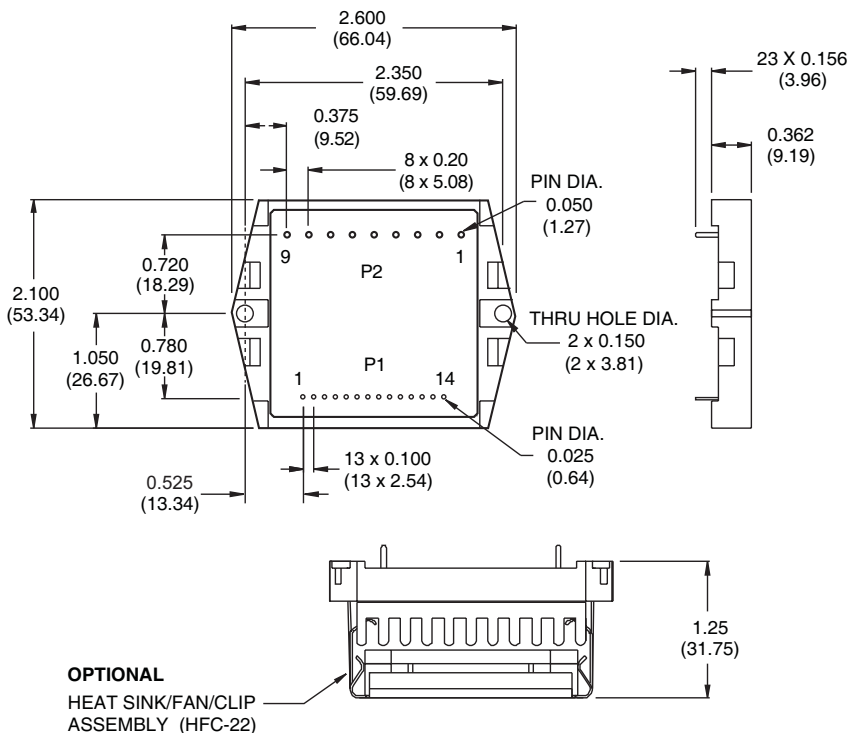

BLOCK DIAGRAM

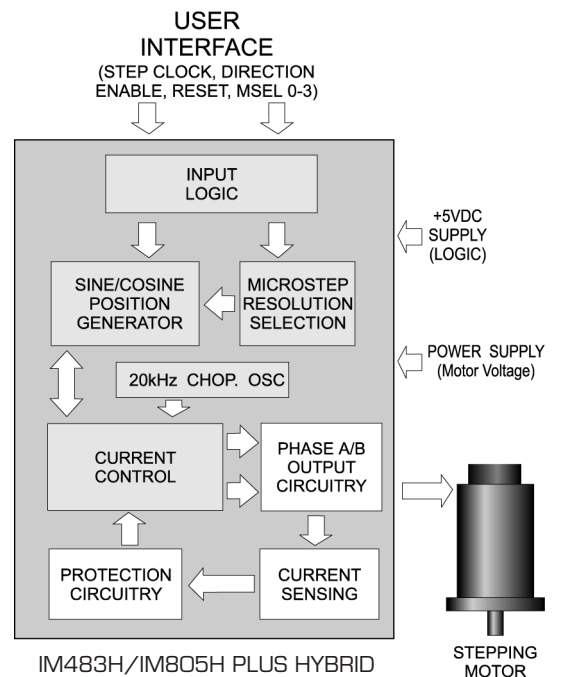

MINIMUM CONNECTIONS

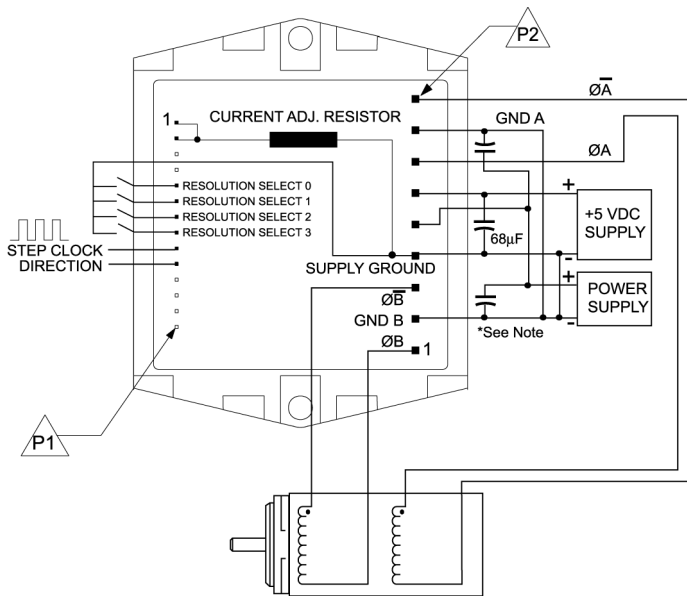

NOTE: Low impedance electrolytic capacitors **MUST** be placed between +V and the phase grounds for each phase (Pins P2: 2 & 8). In addition, a 68mF electrolytic capacitor **MUST** be placed between the +5 VDC output of the +5 volt supply and ground. Capacitors should be placed as close as possible to the driver.

PR-22 RECEPTACLE CARRIER

Disposable plastic frame holds receptacle pins in place for wave or hand solder, then simply pry the plastic frame free and discard.

NOTE: Mounting screws **MUST** be used to secure IM483H/IM805H PLUS when using PR-22 Carrier.

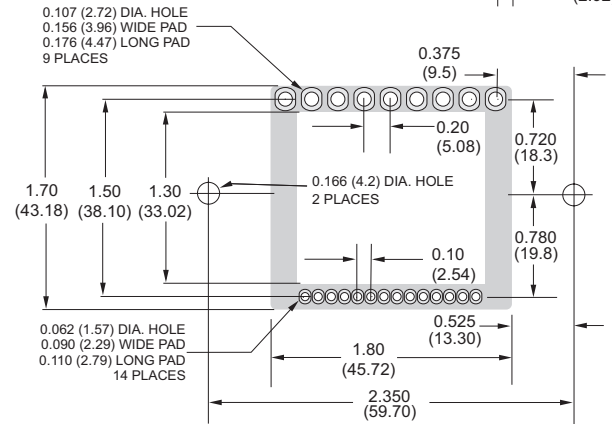
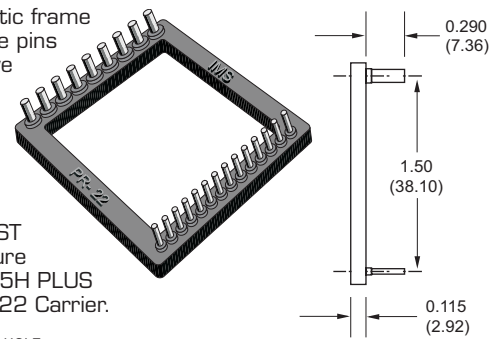

Dimensions in Inches (mm)

DEVELOPER'S KIT/INTERFACE BOARD

The Developer's Kit provides all of the tools needed for rapid prototyping and product evaluation of the IM483H/IM805H PLUS Drivers. Included in the Kit are a Driver, an Interface Board and its schematic, and an HFC-22 assembly. The INT-483H/INT-805H interface board features an on-board +5V supply, additional fault protection,

opto isolation for logic inputs, and removable screw terminals for easy prototyping. The interface board schematic provides a useful guide for PC board layout when completing a system design using the IM483H/IM805H PLUS. The HFC-22 Heat Sink/Fan/Clip Assembly is designed specifically for use with the IM483H/IM805H PLUS and provides a unique, compact cooling solution.

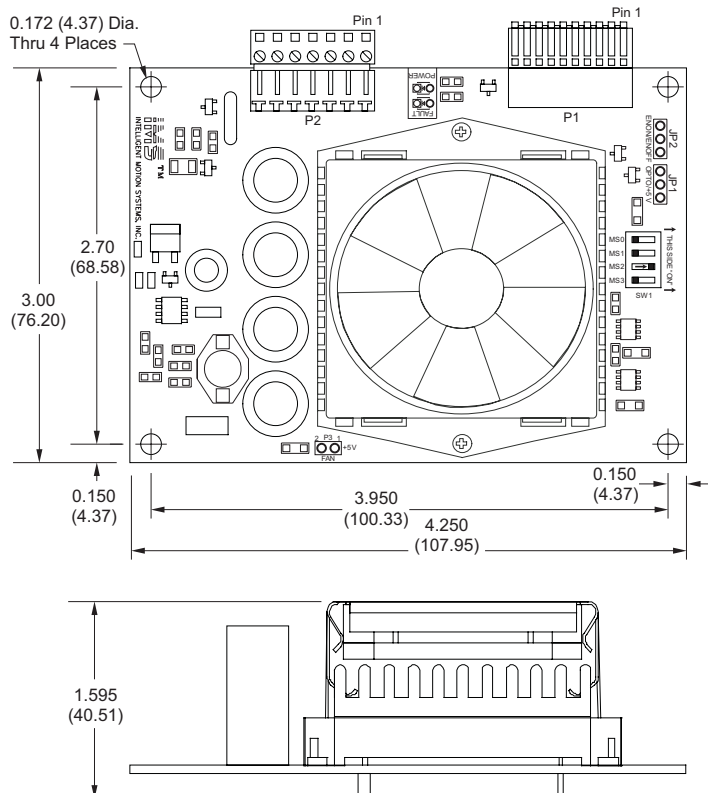

INT-483H/INT-805H Pin Assignments and Descriptions

CONNECTOR P1: 10 POSITION PHOENIX		
PIN	PIN NAME	DESCRIPTION
1	Opto Supply	+5 to +24 VDC
2	Current Reduction	Phase Current Reduction Input
3	Current Adjust	Phase Current Adjust Input
4	Ground	Ground
5	Reset	Active LOW Reset Input
6	Enable	Active HIGH Motor Phase Enable Input
7	Direction	Motor Direction Input
8	Step Clock	Motor Step Clock Input
9	Full Step	Open Drain on Full Step Output
10	Fault	Open Drain Fault Output
CONNECTOR P2: 7 PIN SCREW TERMINAL		
PIN	PIN NAME	DESCRIPTION
1, 2	Phase A	Phase A Output
3, 4	Phase B	Phase B Output
5, 6	Ground	Supply Voltage Ground (Return)
7	+V	Supply Voltage Input