

# SERVO SYSTEMS CO.

## Low Profile Series Heavy Duty Linear Stages

**Model:** HLPS-35-150

**Description:** 35 inch travel linear stage with anti-backlash lead-screw assembly, profiled linear rails, and four (two per rail) linear bearings

**Motor Mount:** Standard NEMA 23

**Dimensions:**

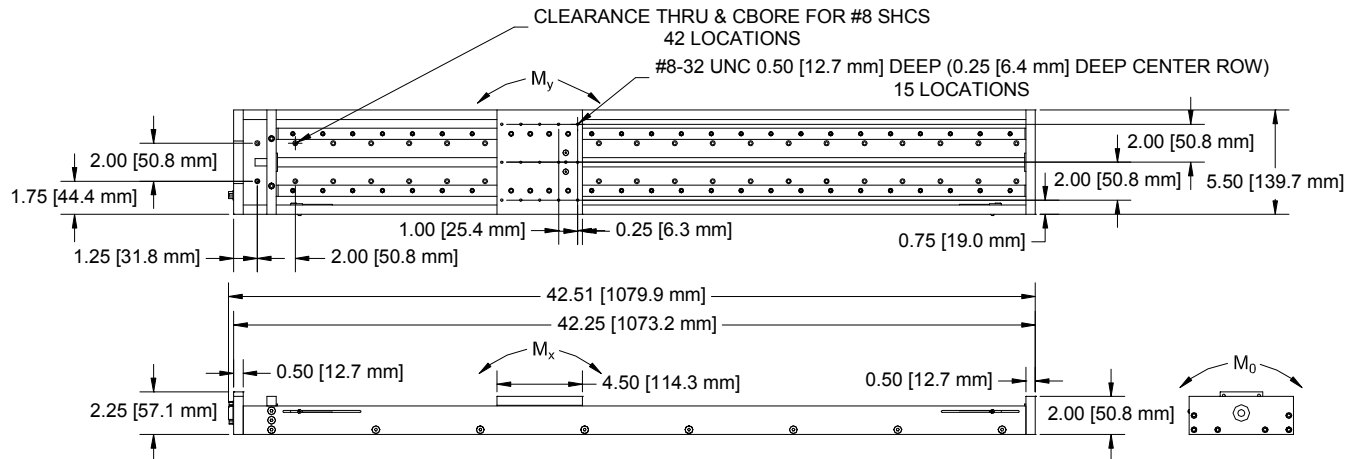

**Specifications:**

<b>Unit Weight</b>	<b>25.6 lb.</b>	<b>Linear Speed</b>	15 in./sec.
<b>Moving Mass</b>	2.285 lb.	<b>Leadscrew Efficiency</b>	84%
<b>Travel Length</b>	35.00 in.	<b>Bidirectional Repeatability</b>	0.0005 in.
<b>Screw Inertia</b>	1.335E-04 lb.-in.-sec. <sup>2</sup>	<b>Pricing Information</b>	<b>HLPS-35-150*</b>
<b>Axial Moment (<math>M_o</math>)</b>	319.40 in.-lb.	<b>Optional Accessories</b>	<b>LPS-MFT*</b> Mounting Foot <b>HLPS-MCH*</b> Manual Crank Handle <b>LPS-MSH*</b> Motor Shaft Crank Handle - fits 1/4" rear motor shaft
<b>Perpendicular Moments (<math>M_x</math> &amp; <math>M_y</math>)</b>	152.75 in.-lb.		
<b>Maximum Dynamic Load</b>	150 lb.		
<b>Payload</b>	147.7 lb.		
<b>Drag Torque</b>	5 oz.-in.		
<b>Standard Lead</b>	1.0 in./rev.		

Notes: Stock screw pitches come in 1 in., .5 in., .25 in., and .2 in.; other screw pitches, motor mount and higher accuracy screws available upon request; dual position limit / home sensors are embedded in the table at no extra fee (see below for more info)

\*Contact Servo Systems Co. via phone or e-mail for pricing information



# SERVO SYSTEMS CO.

## Low Profile Series Heavy Duty Linear Stages (cont'd)

### HLPS Dual Position Limit / Home Sensor Specifications:

<b>Power Consumption</b>	<0.29 W
<b>Max. Switching Current</b>	200 mA
<b>Voltage Drop</b>	<1.8 V
<b>Max. Switching Frequency</b>	2 kHz
<b>Output Indicator</b>	Red LED
<b>Protection Class</b>	IP67 (sensor only)
<b>Connection</b>	9-pin D-sub Male
<b>Pin Function</b>	Pin 1: Supply Voltage (6-30 VDC) Pin 3: Signal Ground Pin 5: Negative Limit (near motor) Pin 7: Positive Limit (far end)