

ED75

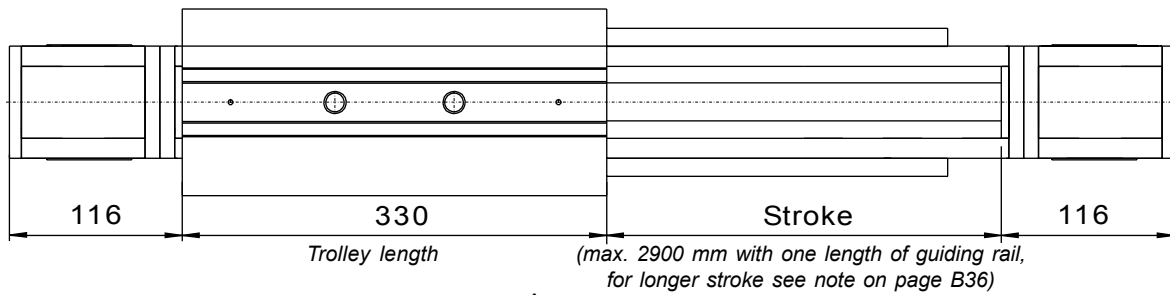

* Position of the T-nuts of our interfaces plates (see pages B32 and B33).

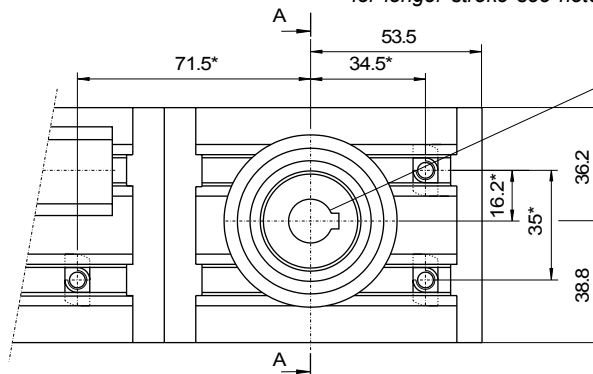

Housing for shaft $\varnothing 14$ h7 with 5x5 key slot **

** In the inch versions (order code suffix "P"), the shaft housing is $\varnothing 5/8$ " with 3/16" x 3/16" key slot.

SPECIAL VERSIONS (upon request):

- $\varnothing 16$ h7 with 5x5 keyway
- $\varnothing 19$ h7 with 6x6 keyway
- $\varnothing 14$ h7 for 14x18 compression coupling
- $\varnothing 19$ h7 for 19x24 compression coupling

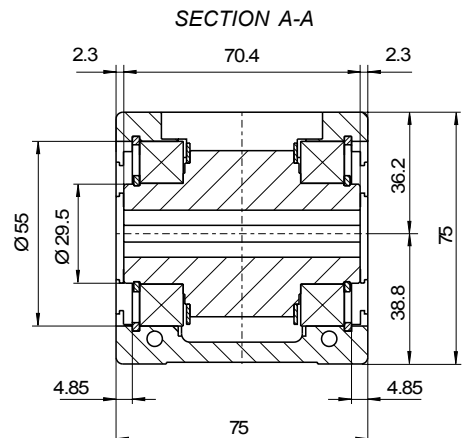
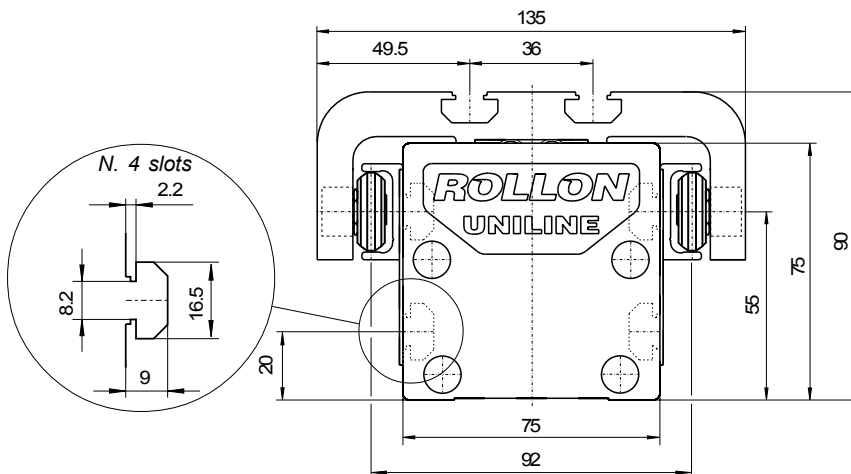

LOAD CAPACITIES

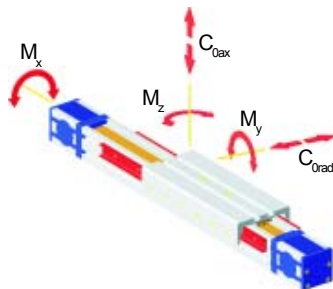

C_{0rad} [N]	C_{0ax} [N]	M_x [Nm]	M_y [Nm]	M_z [Nm]
5500	8700	400.2	696	240

Note: radial load C_{0rad} is considered to be applied along the axis of the internal rail (see page B5).

OTHER FEATURES

Moment of inertia I_y [cm ⁴]	127	Type of slider	CSW43 spec. / CSW28 spec.
Moment of inertia I_z [cm ⁴]	172	Pitch diameter of pulley [m]	0.05093
Max speed [m/s]	5	Moment of inertia of mass of each pulley [gmm ²]	139969
Weight of unit with stroke zero [g]	9850	Mass of belt [g/m]	185
Weight of unit per meter [g]	14400	Max. Belt Tractive Force F_{max} [N]	4480
Mass of slider [g]	3770	Standard belt tension [N]	1000
Stroke for shaft revolution [mm]	160	Standard starting loadless torque [Nm]	1.5
Type of guiding rail	ULV43/ULV28	Belt length [m]	2 x stroke (in m)+ 0.920